

CPX160

16 x 10W Outdoor LED Bar

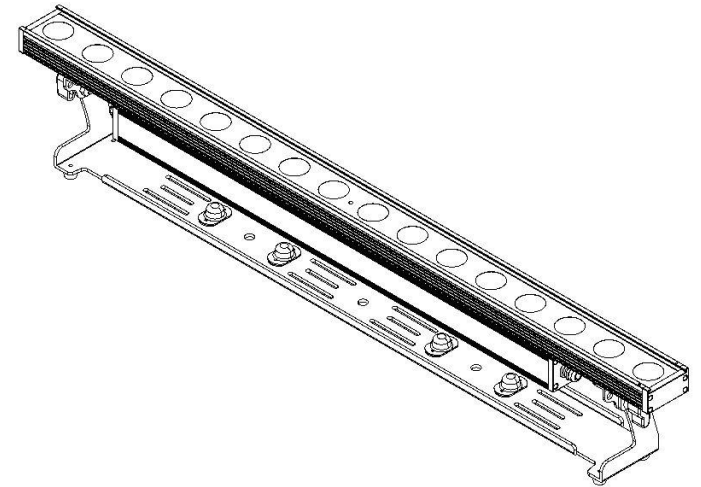
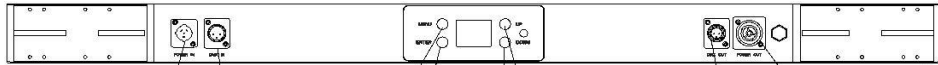
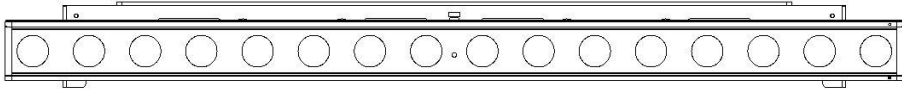

USER MANUAL

Product Overview



POWER-IN DMX-IN MENU ENTER DOWN UP DMX-OUT POWER-OUT

RDM--Remote Device Management

RDM is a wild version of the DMX512-A protocol, allowing dimming stations and other control devices to be discovered through a DMX512 network, and then configuring, status monitoring, and managing intermediate and line end devices.

It allows two-way communication between the lighting device or system controller and the connected RDM compatible device through the standard DMX. This protocol will allow these devices to be configured, monitored, and managed in a manner that does not interfere with the normal operation of standard DMX512 devices that do not recognize the RDM protocol.

Allow a controller or test device to find other devices that can be RDM, such as computer lights or dimming cabinets, and remotely manage them through this connection intelligence. Including the ability to remotely set the initial address of the DMX512, query the device's errors or statistics, and achieve most of the configuration settings that are usually done on the front panel of the device. RDM can run with the new RDM device or any original DMX512 product on the same data link without any performance impact. Since RDM runs on the first DMX512 link, the only infrastructure upgrade required by RDM is to upgrade the existing data distributor to implement a two-way mode to support RDM.

The RDM information is transmitted through the first pair of DMX512 data channels. RDM uses packets that include non-zero initial codes to start and control communications. This alternating (rotating) session and waiting for indicative responses is performed in a semi-duplex format. The second data pair is not used for any RDM function.

Two-way data transmission-each vendor's equipment can exchange data, Art-net can only transmit data, can not exchange with each other.

Its functions are as followed:

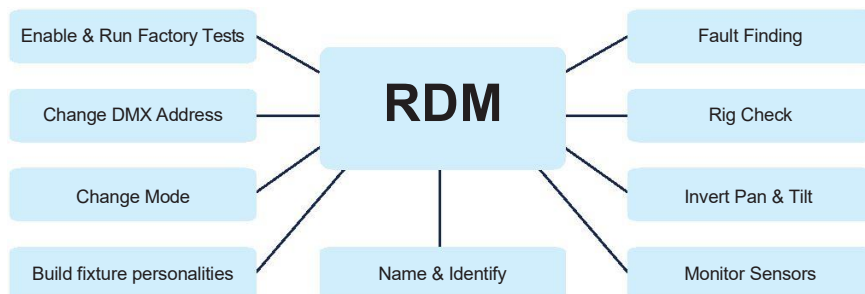

Mechanical Specification

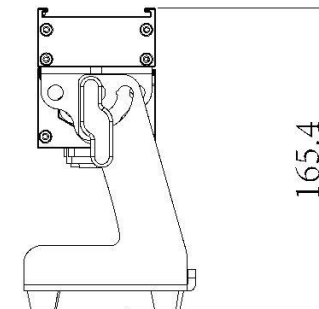
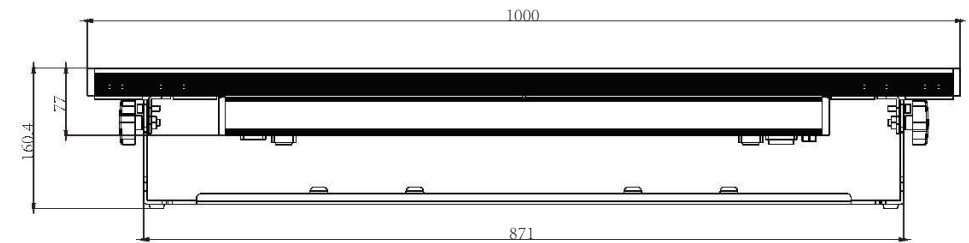

Packaging: Thanks for your purchasing the CPX160. All the lights have been checked and are in excellent operating condition. Please check the shipping carton first. Because there maybe damage occurred during the shipment. Then check the lights carefully and be sure that the light is intact and works normally. In the event damage has been found, spare parts are missing or the lights works abnormally, please contact us for further instructions. And please don't return the light to the dealer before contacting us.

Introduction:The CPX160 has four operating modes: DMX mode, Auto mode, Master/Slave and Sound mode. And the light has seven DMX channel. DMX channel is including 3 channel, 7 channel, 11 channel, 32 channel and 36 channel. You can see 13 kinds of shows when you open the Auto mode .All then all the lights in Master/Slave mode will run following the one in Auto mode. Using fog or special effect smoke, you can see better showing effect.

Warning!

1. For the sake of preventing the risk of electrical shock or fire.
2. Don't look directly at the opening lights all the time, or it may damage your eyes.

IR Controller

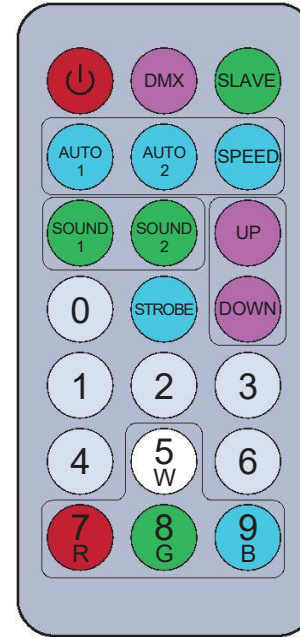

- Power on/off button
- DMX button, to control DMX address when press this button. It is channel mode when double click.
- Master-slave mode button.
- Automatic mode button
- Speed adjustive button

Sound mode button

Up and down button, you can choose the program that you need or numerical.

Strobe button



You can use these number button to adjust numerical in any program mode.

Color choosing button.

CABLE CONNECTORS

Cabling must have a male XLR connector on one end and a female XLR connector on the other end.

DMX connector configuration

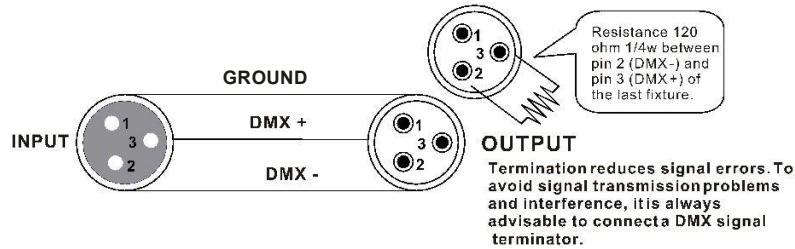

caution: Do not allow contact between the ground and the fixture's chassis ground. Grounding the ground can cause a ground loop, and your fixture may perform erratically. Test cables with an ohm meter to verify positive pole and to make sure the pins are not grounded or shorted to the shield or each other.

3-PIN TO 5-PIN CONVERSION CHART

Note! If you use a controller with a 5 pin DMX output connector, you need to use a 5 pin to 3 pin adapter. The chart below details a proper cable conversion:

3-PIN TO 5-PIN CONVERSION CHART

Conductor	3 Pin Female (output)	5 Pin Male (Input)
Ground/Shield	Pin 1	Pin 1
Data (-) signal	Pin 2	Pin 2
Data (+) signal	Pin 3	Pin 3
Do not use		Do not use
Do not use		Do not use

Features

- Light Source: 16pcs*10W, RGBW 4 in 1 LED
- Beam angel: 20 °
- Power consumption: 120W
- DMX channels: 3, 8, 12, 32, & 37 CH
- DMX and RDM is available.
- IR remote control included
- Power in and out: Seetronic IP65 true 1 power input and output;
- DMX in and out: Seetronic IP65 XLR input and output
- Fix installation: IP65 power in and out cable. IP65 DMX in and out cable.
- Four button with TFT LED displayer
- Body angel: 0 to 90°
- Fast connection between two lights in one line (Extra accessory)
- Splicing connectors (Extra accessory)
- Optional accessory: frost filter, Barndoor, and Shell frost filter for rainbow effect.
- Bracket: Stage use - One bracket with omega lock. Fix installation - Two bracket on the two side with body angel direction.
- Temperature protection
- Aluminium body and die-cast cover. Anti UV and salt coat painting.
- Waterproof: IP65
- Product dimension: 1000mm(L)* 90mm(W)* 113mm(H)
- GW: 5.5NW

Accessory

- ① Barndoor x 1 (purchase separate)
- ② Magnetic frost filter x 1 (purchase separate)
- ③ Power cable x 1
- ④ DMX cable x 1
- ⑤ User manual x 1
- ⑥ IR Controller x 1
- ⑦ Fastlock x 2

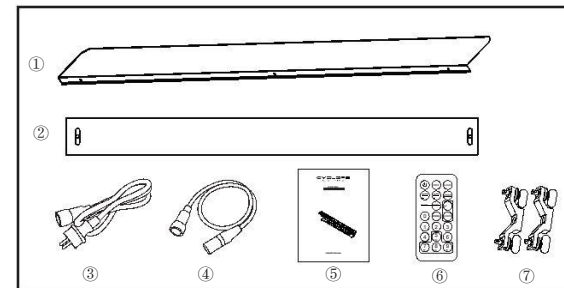

Displayer introduction

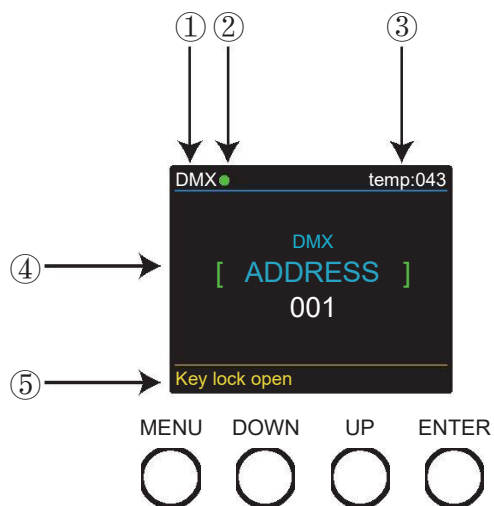

1. DMX means the light is in the DMX mode. Similarly, SLAVE means the light is in the SLAVE mode.
2. The color of the point shows the condition of signal transmission. Green represents the good condition, while red represents the signal is interrupted.
3. The item shows the working temperature of the light. When the working temperature exceeds the max temperature, the color of the letters and number will change from white to yellow.
4. This item shows the menu you selected.
5. This item shows the condition of key lock. "Key lock open" means the key lock is open. And "Key lock off" means the key lock is close.

Mounting

When installing the unit, the trussing or area of installation must be able to hold 10 times the weight without any deformation. When installing the unit must be secured with a secondary safety attachment, e.g. and appropriate safety cable. Never stand directly below the unit when mounting, removing, or servicing the unit.

Overhead mounting requires extensive experience, including calculating working load limits, installation material being used, and periodic safety inspection of all installation material and unit. If you lack these qualifications, do not attempt the installation yourself.

The installation should be checked by a skilled person once a year.

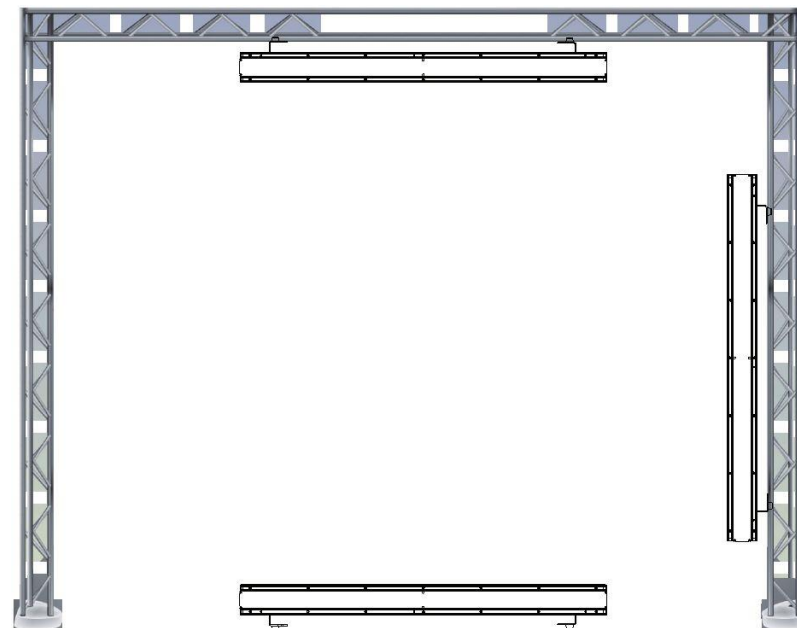

The CPX160 is fully operational in three different mounting positions, hanging upside-down from a ceiling, set on a flat level surface or mount the unit on its side. Be sure this fixture is kept at least 0.5m away from any flammable materials (decoration etc.). And you'd better use and install the supplied safety cable as a safety measure to prevent accidental damage and/or injury in the event the clamp fails (see next page).

INFORMATION-In this menu, you can learn about the information of RDM, software and hardware of the light.

1. Press "ENTER" and then press "UP" or "DOWN" to "INFORMATION".
2. Press "ENTER" and you can see 3 items as below:
 - 1) RDM - It shows RDM information.
 - 2) Hardware - It shows the Hardware information.
 - 3) Software - It shows the Software information.

WIRELESS-In this menu, you can set the Wireless signal.

1. Press "ENTER" and then press "UP" or "DOWN" to "WIRELESS".
2. Press "ENTER" and then choose "ON" or "OFF" to set the Wireless signal. "ON" is turn on the signal and "OFF" is turn off the signal.

FACTORY RESET-In this menu, you can reset all the value of the system.

1. Press "ENTER" and then press "UP" or "DOWN" to "FACTORY RESET".
2. Press "ENTER" to reset all the values of the system.

Programme Menu

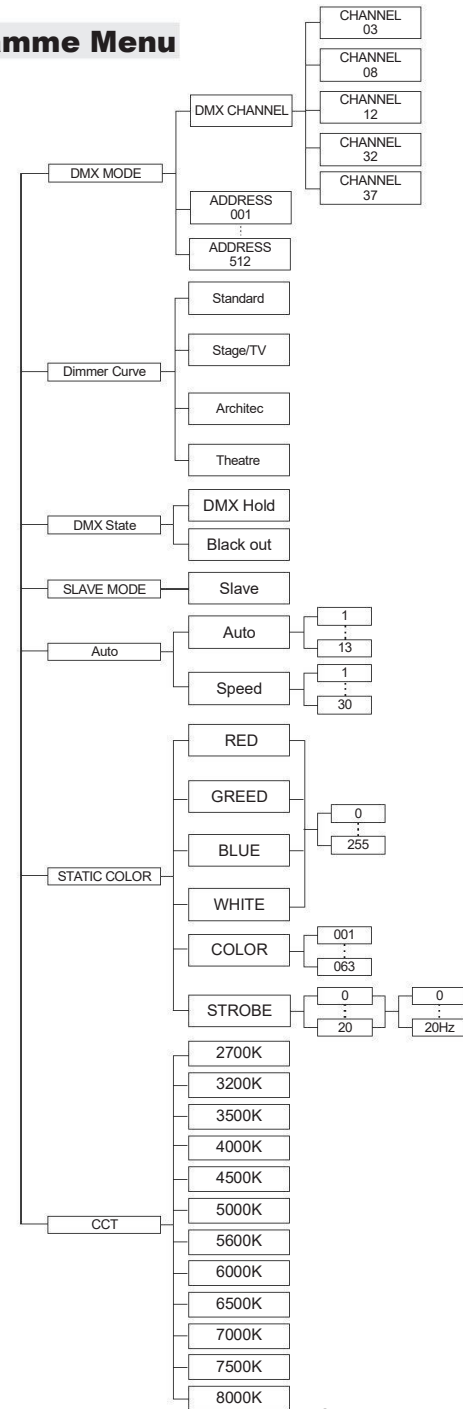

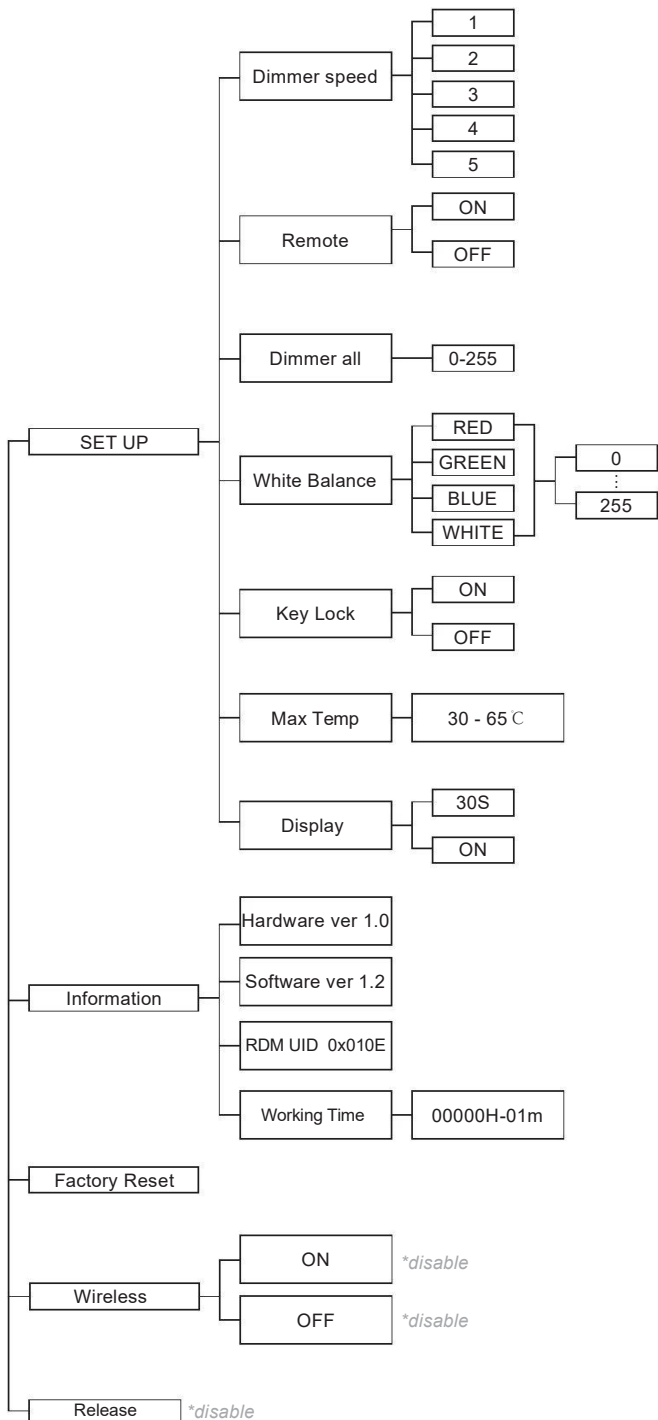

DMX MODE-In this menu,you can connect several pieces of lights with DMX cable and control them with the control console.

Press "ENTER" and then press "UP" or "DOWN" to "Address" or "DMX Channel" and press "ENTER".
 1) "XXX" will be showed in "Address", "XXX" means the Address 001-512. You can press "UP" or "DOWN"to select the address you desired.
 2) "Channel [xx]" will be showed in "DMX Channels", "XX" means 5 kinds of DMX Channels Modes. You can press "UP" or "DOWN" to select the Channel Mode you desired.

DIMMER CURVE-In this menu,you can choose the mode you desired.

1. Press "ENTER" and then press "UP" or "DOWN" to "Dimmer Curve" to choose as below modes.
 2. Press "ENTER" you can see 4 items as below:
 1) Standard
 2) Stage/TV
 3) Architec
 4) Theatre

DMX STATE-In this menu,you can choose the DMX signal you desired.

1. Press "ENTER" and then press "UP" or "DOWN" to "DMX STATE".
 2. Press "ENTER" and you can choose "BLACKOUT" or "DMX HOLD" ; "BLACKOUT" means cut off the DMX signal and "DMX HOLD" means connect DMX signal.

SLAVE MODE-In this menu, you can choose one light as the MASTER light and other lights in SLAVE Mode will run follow the MASTER light.

1. Press "ENTER" and then press "UP" or "DOWN" to "SLAVE Mode".
 2. Press "ENTER" and "SLAVE" will be showed, then press "ENTER" to choose.

AUTO MODE-In this menu, you can choose your desired AUTO Mode and adjust the running speed.

1. Press "ENTER" and then press "UP" or "DOWN" to "AUTO MODE".
 2. Press "ENTER" you can see 2 items as below:
 1) SPEED - It provides "01-31" for you choose.
 2) AUTO MODE - It provides "AUTO 1- AUTO 13" for you choose.

STATIC COLOR-In this menu,you can choose the modes you need.

1. Press "ENTER" and then press "UP" or "DOWN" to "AUTO MODE".
 2. Press "ENTER" you can see 8 items as below:
 1) RED
 2) GREEN
 3) BLUE
 4) WHITE
 5) AMBER
 6) UV
 7) COLOR - You can choose "1-63" in this menu.
 8) STROBE - You can choose "0-20" in this menu.

CCT-In this menu, you can choose the brightness you desired.

1. Press "ENTER" and then press "UP" or "DOWN" to "CCT".
 2. Press "ENTER" you can chooose from "2700K" to "8000K" as you need.

SET UP-In this menu, you can adjust the values of the function.

1. Press "ENTER" and then press "UP" or "DOWN" to "SET UP".
 2. Press "ENTER" and there has 6 options then press "ENTER" to choose the options and press "UP" or "DOWN" to choose the value you desired as below:
 1) IR - You can press "ON" or "OFF" to choose whether you need to controll by this mode.
 2) Dimmer All - You can adjust the brightness of colors.
 3) Wihte Balace - You can select "RED" "GREEN" "BLUE" "WHITE" you need.
 4) Key Lock - You can choose "ON" or "OFF" to make the Key Lock turn on or off.
 5) Display - You can choose "ON" or "30s" to make the position of the light screen.
 6) Max temp - You can set the your desired Max working temperature of the light with passcode in this menu.When the working temperature beyond max temperature of default settings, the color of letter "Temp XX" will show the color from white to yellow.Meanwhile, the light will adjust the working temperature automatically.

DMX-512 addressing with ID address

1. Follow instructions 1 for DMX 512 addressing.
2. Activate ID addressing in each fixture by setting panel function "ID ON/OFF" to ON. "Settings" to "ID ON/OFF" to "ON" For every DMX 512 starting address the user can set 66 separate ID addresses. Set ID addresses in each fixture by setting panel function " ID address" to incremental values.(I.e. 1, 12, 24, 36 etc...) "Settings" to "address" to "01~66".

DMX address: 001 DMX address: 001 DMX address: 001 DMX address: 012 DMX address: 012 DMX address: 012
 ID address: 01 ID address: 02 ID address: 03 ID address: 01 ID address: 02 ID address: 03

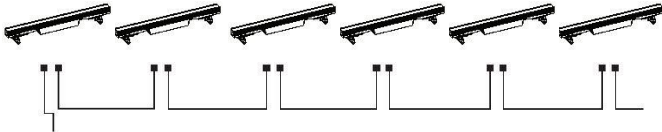

The figure above shows a simple DMX layout which has used three units at each DMX address. The three units have different ID addresses which allows the user to collectively control the whole group of units at that DMX address by setting Channel 10 to 0, or to control each unit independently by first selecting the DMX address and then by using Channel 11 to locate the target ID address. (Note that when using ID addresses it is also possible to activate ADAS which allows for even more option with DMX addressing and control.

UPLOAD

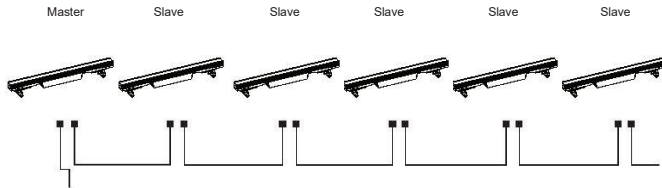

First, set one light, which involves the program you have edited in EDIT menu and want to upload, in Master mode, and others in Slave mode. Then, connect all the lights with DMX cables. Finally, select the UPLOAD menu of the Master light and press ENTER. All the programs edited in the Master light will be uploaded to the Slave lights.

DMX control mode

MODE3 CHANNELS		
Channel	Value	Function
1	000 - 255	HUE
2	000 - 255	Saturation
3	000 - 255	Value

MODE 8 CHANNELS		
Channel	Value	Function
1	000 - 255	Dimmer
2	001 - 063	Dimmer Curve1
	064 - 127	Dimmer Curve2
	128 - 191	Dimmer Curve3
	192 - 255	Dimmer Curve4
3	001 - 005	No fuction
	006 - 049	Dimmer speed 1
	050 - 099	Dimmer speed 2
	100 - 149	Dimmer speed 3
	150 - 199	Dimmer speed 4
	200 - 255	Dimmer speed 5
4	000 - 255	Red
5	000 - 255	Green
6	000 - 255	Blue
7	000 - 255	White
8	000 - 255	Strobe

MODE 12 CHANNELS		
Channel	Value	Function
1	000 - 255	Dimmer
2	001 - 063	Dimmer Curve1
	064 - 127	Dimmer Curve2
	128 - 191	Dimmer Curve3
	192 - 255	Dimmer Curve4
3	001 - 005	No fuction
	006 - 049	Dimmer Curve1
	050 - 099	Dimmer Curve2
	100 - 149	Dimmer Curve3
	150 - 199	Dimmer Curve4
	200 - 255	Dimmer Curve5
4	000 - 255	Red
5	000 - 255	Green
6	000 - 255	Blue
7	000 - 255	White
8	000 - 255	Strobe
9	000 - 255	color
10	000 - 255	CCT
11	000 - 255	Auto 1-13
12	000 - 255	speed slow -fast

MODE 32 CHANNELS		
Channel	Value	Function
1	000 - 255	Led1 Red
2	000 - 255	Led1 Green
3	000 - 255	Led1 Blue
4	000 - 255	Led1 White
5	000 - 255	Led2 Red
6	000 - 255	Led2 Green
7	000 - 255	Led2 Blue
8	000 - 255	Led2 White
9-12	000 - 255	Led3 RGBW
13-16	000 - 255	Led4 RGBW
17-20	000 - 255	Led5 RGBW
21-24	000 - 255	Led6 RGBW
25-28	000 - 255	Led7 RGBW
29-32	000 - 255	Led8 RGBW

MODE 37 CHANNELS		
Channel	Value	Function
1	000 - 255	Dimmer
2	001 - 063	Dimmer Curve1
	064 - 127	Dimmer Curve2
	128 - 191	Dimmer Curve3
	192 - 255	Dimmer Curve4
3	001 - 005	No fuction
	006 - 049	Dimmer speed 1
	050 - 099	Dimmer speed 2
	100 - 149	Dimmer speed 3
	150 - 199	Dimmer speed 4
	200 - 255	Dimmer speed 5
4	000 - 255	Auto 1-13
5	000 - 255	speed slow -fast/strobe
6	000 - 255	Led1 Red
7	000 - 255	Led1 Green
8	000 - 255	Led1 Blue
9	000 - 255	Led1 White
10	000 - 255	Led2 Red
11	000 - 255	Led2 Green
12	000 - 255	Led2 Blue
13	000 - 255	Led2 White
14-17	000 - 255	Led3 RGBW
18-21	000 - 255	Led4 RGBW
22-25	000 - 255	Led5 RGBW
26-29	000 - 255	Led6 RGBW
30-33	000 - 255	Led7 RGBW
34-37	000 - 255	Led8 RGBW

Channel 37 (Id address set)

0--9	all Ids	170--179	Id17	223	Id34	240	Id51
10--19	Id1	180--189	Id18	224	Id35	241	Id52
20--29	Id2	190--199	Id19	225	Id36	242	Id53
30--39	Id3	200--209	Id20	226	Id37	243	Id54
40--49	Id4	210	Id21	227	Id38	244	Id55
50--59	Id5	211	Id22	228	Id39	245	Id56
60--69	Id6	212	Id23	229	Id40	246	Id57
70--79	Id7	213	Id24	230	Id41	247	Id58
80--89	Id8	214	Id25	231	Id42	248	Id59
90--99	Id9	215	Id26	232	Id43	249	Id60
100--109	Id10	216	Id27	233	Id44	250	Id61
110--119	Id11	217	Id28	234	Id45	251	Id62
120--129	Id12	218	Id29	235	Id46	252	Id63
130--139	Id13	219	Id30	236	Id47	253	Id64
140--149	Id14	220	Id31	237	Id48	254	Id65
150--159	Id15	221	Id32	238	Id49	255	Id66
160--169	Id16	222	Id33	239	Id50		