



FLG-5 Heavy Fog Liquid

F-3 Fazer

The new stackable Antari F-3 Fazer integrates the features of a rugged flight case in its new packable design.

The state-of-the-art air pump system mixes fog and air to produce a fine, dry fog with minimal fluid consumption, for example, one liter of Antari's FLG heavy fog liquid will provide five hours of continuous fogging.

Performance meets reliability in this new design: the extremely dry fog output leaves no residue, and no liquid is left inside the heater, achieving a longer life cycle for this critical component.

The F-3 also features built-in DMX functionality and silent operation, making it suitable for the widest variety of theatrical and stage applications.

F-3 Fazer Specification

- » Power : AC100V/AC120V/AC230V/AC240V,50Hz-60Hz
- » Heater : 800W
- » Output : 3000 cu.ft / min
- » First Heat-up Time : 100 Sec
- » Fluid Consumption : 5 hr / liter (100% Output)
- » Tank Capacity : 2.7 liter
- » Control : Blue LCD screen , Timer mode , Volume mode
- » Weight : 20.5 Kg
- » Dimensions (mm) : L 550 W 508 H 236
- » DMX : On board
- » DMX Channel Occupied : 2 Channels (one for fog output; one for fan output)

Liquid

- » Use only FLG (Heavy Fog Liquid) for best F-3 effects
- Fog liquid with no oily residue and longer lifespan for the machines.



Control Panel (LCD Screen, DMX Neutrik PowerCon)



F-3 Fazer Effect (Horizontal)



F-3 Fazer Effect (Vertical)

DFOG

IP-1500



FLG-5
Heavy Fog Liquid



FLR-5
Light Fog Liquid

IP-1500 Fog Machine

The IP-1500 is Antari's newest waterproof fog machine, incorporating an innovative new design that earns it an IP-63 rating. Whether indoor or outside, the new IP-1500 delivers massive fog output with its state-of-the-art design and 1500 watts of power.

Included in that design is an extremely precise temperature control system, highly efficient heat conservation system, and an acutely sensitive liquid detection system that senses when fog output or liquid supply is running low.

When using the IP-1500 outdoors, even when raining, it is capable of detecting the ambient temperature and adjusting its operating parameters accordingly. Of course, both DMX and wireless remote options also come standard with this professional machine.

The new IP-1500 was designed with efficiency in mind and achieves 13% less electricity consumption than other foggers in its size class, making it the greenest choice.



• Control Panel



• IP-1500 Effect



• W-1 Wireless Transmitter

IP-1500 Fog Machine Specification

- » Power : AC100V/AC120V/AC230V/AC240V,50Hz-60Hz
- » Heater : 1500 W
- » Output : 20,000 cu.ft / min
- » First Heat-up Time : 10 min
- » Fluid Consumption : 11 min / liter (100% Output)
- » Remote Included : W-1 Wireless Transmitter
- » Control : Blue LCD screen , Timer mode , Volume mode , Wireless Remote
- » Weight : 13.5 Kg
- » Dimensions (mm) : L 450 W 220 H 180
- » DMX : On board

W-1 Wireless Radio Transmitter

- » Working Distance : Wireless , up to 50 M
- » Function : Wireless ON/OFF

Liquid

- » Recommended Antari FLR/FLG
- High quality and performance, environmental-friendly.
- Fog liquid with no oily residue and longer lifespan for the machines.

HZ-350



HZL-1
Haze Liquid

HZ-350 Haze Machine

HZ-350, a brand new haze machine from Antari with not only the reliable quality as a tradition but also new charming features!

With the innovative LCD control panel built in the machine, now you can master this classic haze machine without effort at all. The digital LCD control system now allows users to set the timer and DMX address directly and accurately by just moving their fingertips.

Furthermore, wireless on/off control is another excitement for users who need to execute the output timing with their own hands.

Now just try it to believe it!



• Control Panel



• W-1 Wireless Transmitter



• HC-1 Timer Remote (Optional)



• HZ-350 Effect

HZ-350 Haze Machine Specification

- » Power : AC100V/AC120V/AC230V/AC240V,50Hz-60Hz
- » Output : 2,000 cu.ft / min
- » Tank Capacity : 2.5 liter
- » Fluid Consumption Rate : 21 hr / liter
- » Remote Included : W-1 Wireless Transmitter
- » Optional Remotes : HC-1 Timer Remote
- » Air Pressure : 30 Psi
- » Weight : 14.2 Kg
- » Dimensions (mm) : L 491.8 W 273 H 314.5
- » DMX : On board

W-1 Wireless Radio Transmitter

- » Working Distance : Wireless , up to 50 M
- » Function : Wireless ON/OFF

HC-1 Timer Remote (Optional)

- » Cable Length : 25 ft
- » Connector : 1/4 Stereo
- » Function : Timer with interval and duration; manual ON/OFF

Liquid

- » Optimized for use with all Antari Haze machines. This oil-based HZL-1 produces translucent haze with long hanging time.

SNOW WIRELESS
SW-250



SL-5A
Snow Liquid Premium



SL-5
Snow / Foam Liquid

SW-250 Wireless Control High Output Snow Machine

Are you looking for snow machine with wireless control? Are you looking for snow machine which can generate higher volume of snow output? If you need either or both of above features for snow machine, then Antari SW-250 is your best solution.

SW-250 is not only a completely digitalized snow machine with on-board DMX and wireless control, but also can create a real blizzard effect.

Compare to its predecessors, S-100II & S-200, its snow output is increased about 250% at maximum.

In addition, timer and volume (1~100% output) control functions allow you to control the snowflakes effect even more accurately.

No doubt. Antari SW-250 is the best answer to all kinds of snow effects requests.

SW-250 Snow Machine Specification

- » Power : AC100V/AC120V/AC230V/AC240V,50Hz-60Hz
- » Power Consumption : 600W (Min Output) , 1290 W (Max Output)
- » Output : 250 ml / min
- » Tank Capacity : 5 liter
- » Fluid Consumption Rate : 4 min / liter (100% Output)
- » Remote Included : W-1 Wireless Transmitter
- » Accessory Include : Hanging Bracket
- » Weight : 12.6 Kg
- » Dimensions (mm) : L 554 W 276 H 228
- » DMX : On board

W-1 Wireless Radio Transmitter

- » Working Distance : Wireless , up to 50 M
- » Function : Wireless ON/OFF

SC-2 Remote (Optional)

- » Cable Length : 25 ft
- » Connector : 4 Pin XLR
- » Function : ON/OFF and volume

Liquid

- » Optimized for use with Antari Snow Machines
- SL-5 : water-based snow liquid for accumulated snowflake effect
- SL-5A : water-based snow liquid for fast disappearing



• Control Panel



• S-250 Effect



• W-1 Wireless Transmitter



• SC-2 Remote (Optional)

FLG-5
Heavy Fog LiquidFLR-5
Light Fog Liquid

W-515 / W-530 Wireless Control Fog Machine

The cutting-edge wireless control system gives Antari W series a simple setting and operation interface. Additionally, the state-of-the-art heater design upgrades the W Series fog machines to a higher level in terms of good quality fog and energy efficiency. In conclusion, Antari W Series bring users to a professional scene in an easier method.

Main Features:

- 1. Intelligent Wireless Control System**
Each machine comes with a set of wireless receiver and transmitter as standard controller. The working distance of wireless control is 50 meters in open area.
- 2. Opto-electronic Fluid Sensor**
When the fluid recipient runs dry, the fluid sensor stops pumping automatically to protect pump from burning.
- 3. More Efficient New Heat Exchanger Design**
It can generate drier fog with smaller particles. This leads to a fairly low fog fluid consumption. Compare to the equivalent power consumption heat exchangers, the same quantity of fog fluid in W series can produce 20% more fog than others.
- 4. New Advanced PCB (Printed Circuit Board)**
Design The new system can control temperature precisely and rule out the influence from outside environments as much as possible to make W series fog machines be able to work stably between - 20 and + 60 degree Celsius.

W-515 Wireless Control Fog Machine Specification

- » Power : AC100V/AC120V/AC230V/AC240V,50Hz-60Hz
- » Heater : 1,500 W
- » Output : 20,000 cu.ft / min
- » First Heat-up Time : 10 min
- » Tank Capacity : 6 liter
- » Fluid Consumption Rate : 8.3 min / liter (100% Output)
- » Remote Included : W-1 Wireless Remote
- » Optional Accessories : FW-500 Flight Case , W-515-HB Hanging Bracket
- » Weight : 14 Kg
- » Dimensions (mm) : L 561 W 278 H 186

W-530 Wireless Control Fog Machine Specification

- » Power : AC230V/AC240V,50Hz-60Hz
- » Heater : 3,000 W
- » Output : 40,000 cu.ft / min
- » First Heat-up Time : 12 min
- » Tank Capacity : 6 liter
- » Fluid Consumption Rate : 5.3 min / liter (100% Output)
- » Remote Included : W-1 Wireless Remote
- » Optional Accessories : FW-500 Flight Case , W-515-HB Hanging Bracket
- » Weight : 19 Kg
- » Dimensions (mm) : L 581 W 278 H 186
- » Wireless DMX is optional for both W-515 & W-530

W-1 Wireless Radio Transmitter

- » Working Distance : Wireless , up to 50 M
- » Function : Wireless ON/OFF

Liquid

- » Recommended Antari FLR/FLG High quality and performance, environmental-friendly. Fog liquid with no oily residue and longer lifespan for the machines.

• Control Panel
(LCD Screen)• Neutrik
PowerCON

• W-515 Effect

• W-1 Wireless
Transmitter

FLG-5
Heavy Fog LiquidFLR-5
Light Fog Liquid

W-508 / W-510 Wireless Control Fog Machine

The cutting-edge wireless control system gives Antari W series a simple setting and operation interface. Additionally, the state-of-the-art heater design upgrades the W Series fog machines to a higher level in terms of good quality fog and energy efficiency. In conclusion, Antari W Series bring users to a professional scene in an easier method.

Main Features:

- 1. Intelligent Wireless Control System**
Each machine comes with a set of wireless receiver and transmitter as standard controller. The working distance of wireless control is 50 meters in open area.
- 2. Opto-electronic Fluid Sensor**
When the fluid recipient runs dry, the fluid sensor stops pumping automatically to protect pump from burning.
- 3. More Efficient New Heat Exchanger Design**
It can generate drier fog with smaller particles. This leads to a fairly low fog fluid consumption. Compare to the equivalent power consumption heat exchangers, the same quantity of fog fluid in W series can produce 20% more fog than others.
- 4. New Advanced PCB (Printed Circuit Board) Design**
The new system can control temperature precisely and rule out the influence from outside environments as much as possible to make W series fog machines be able to work stably between - 20 and + 60 degree Celsius.

W-508 Wireless Control Fog Machine Specification

- » Power : AC100V/AC120V/AC230V/AC240V,50Hz-60Hz
- » Heater : 800 W
- » Output : 3,000 cu.ft / min
- » First Heat-up Time : 100 seconds
- » Tank Capacity : 0.8 liter
- » Fluid Consumption Rate : 60 min / 0.8liter (100% Output)
- » Remote Included : W-1 Wireless Remote
- » Weight : 3.8 Kg
- » Dimensions (mm) : L 315 W 128 H 166

W-510 Wireless Control Fog Machine Specification

- » Power : AC100V/AC120V/AC230V/AC240V,50Hz-60Hz
- » Heater : 1,000 W
- » Output : 10,000 cu.ft / min
- » First Heat-up Time : 11 min
- » Tank Capacity : 2.8 liter
- » Fluid Consumption Rate : 11 min / liter (100% Output)
- » Remote Included : W-1 Wireless Remote
- » Optional Accessories : W-510-HB Hanging Bracket
- » Weight : 11.4 Kg
- » Dimensions (mm) : L 468 W 250 H 148
- » DMX : On board

W-1 Wireless Radio Transmitter

- » Working Distance : Wireless , up to 50 M
- » Function : Wireless ON/OFF

Liquid

- » Recommended Antari FLR/FLG High quality and performance, environmental-friendly. Fog liquid with no oily residue and longer lifespan for the machines.



• W-508 Rear Panel

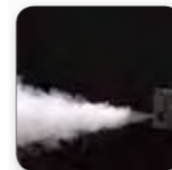

• W-508 Effect



• W-510 Rear Panel

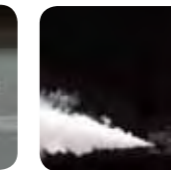

• W-510 Effect

W-101 Bubble



BL-5
Bubble Liquid

W-101 Wireless Control Bubble Machine

The cutting-edge wireless control system gives Antari W-101 bubble machine a simple setting and operation interface. It brings users to a professional scene in an easier method.

Main Features:

1. Intelligent Wireless Control System
Each W-101 bubble machine comes with a set of wireless receiver and transmitter as standard controller. The working distance of wireless control is 50 meters in open area.
2. Texture-like Painting Finish
Though most of the time, bubble machines are served as supportive character at the corner of stage, W-101 bubble machine is now given extraordinary elegant finish as a star!

W-101 Wireless Control Bubble Machine Specification

- » Power : AC100V/AC120V/AC230V/AC240V,50Hz-60Hz
- » Power Consumption : 25 W
- » Tank Capacity : 1 liter
- » Fluid Consumption Rate : 2 hr / liter
- » Remote Included : W-1 Wireless Remote
- » Weight : 4.8 Kg
- » Dimensions (mm) : L 340 W 170 H 172

W-1 Wireless Radio Transmitter

- » Working Distance : Wireless , up to 50 M
- » Function : Wireless ON/OFF

Liquid

- » Optimized for use with Antari Bubble Machines
- BL-5 : Water-Based bubble liquid that creates vivid bubbles for any occasions.

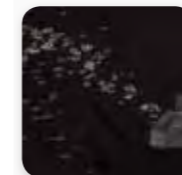

• W-101 Effect



• Rear Panel



• W-101 Bubble Machine



• W-1 Wireless Transmitter

DFOG

IP-1000



FLG-5
Heavy Fog Liquid



FLR-5
Light Fog Liquid

IP-1000 , IP-Rated Fog Machine

This brand-new IP-1000 has been a breakthrough from the past models that are only limited in indoor usage.

1000W fog machine featuring a sleek stainless exterior that renders this powerful fog machine impervious to both dust and water spray. This new IP-63 rated model represents both a technical and aesthetic advancement, melding an appealing fresh form and groundbreaking practical functionality in a new unit suitable for a wide range of club, installation, retail and leisure applications and beyond. Combining the solid performance for which Antari fog machines are known with leading edge enhancements, the IP-1000 spray-proof fog machine is an exciting addition to the Antari line.

Main Features:

1. Stainless steel case makes it perfect for operating in outdoor with damp condition.
2. Typical Antari quality heat exchanger generates pure and dry fog.
3. To give you the flexibility of installation and maximize the duration of continuous operation, IP-1000 does not come with an attached fog fluid tank. With a 10 meter long fog fluid tube coming along with IP-1000, you can deploy your fluid tank at any place where is most convenient for you. You can also use a huge fog fluid tank (not included with the original package) to enable your expected continues operation time.



• IP-1000 Effect



• Rear Panel



• IP-10 Remote

IP-1000 Fog Machine Specification

- » Power : AC100V/AC120V/AC230V/AC240V,50Hz-60Hz
- » Heater : 1,000 W
- » Output : 10,000 cu.ft / min
- » First Heat-up Time : 11 min
- » Fluid Consumption Rate : 11 min / liter (100% Output)
- » Remote Included : IP-10 Remote
- » Weight : 8.8 Kg
- » Dimensions (mm) : L 355 W 250 H 148

IP-10 Remote

- » Cable Length : 25 ft
- » Function : ON/OFF

Liquid

- » Recommended Antari FLR/FLG
High quality and performance, environmental-friendly.
Fog liquid with no oily residue and longer lifespan for the machines.

M-10
STAGE FOGGER

M-5
STAGE FOGGER



FLG-5 Heavy Fog Liquid

FLR-5 Light Fog Liquid

The M-Series / Stage Fog Machine M-5 & M-10

This high performance heavy-duty M-5 & M-10 Stage Fog Machine from Antari are uniquely designed to meet the rigorous demands of stage and touring use: a high-capacity 10 liter tank offers long time operation.

A rectangular, durable sleek housing design makes the Antari M-Series Stage Fog Machine easy to carry and be able to stand with tough road transport (Anti-shock) where custom flightcases come optional for your application. Due to its enhanced heat reservation structure, it reduces electricity consumption for about 20 ~ 25% yet producing more powerful fog. They will stand the rigors of professional use as well as protection against unexpected water spills and changing weather conditions.

There are 2 professional choices M-5 (1500W) and M-10 (3000W). They have DMX on-board and can be controlled remotely with a digital M-20 LCD display module, enabling convenient remote operation. DMX connection can be worked by either 3 or 5 pin connector.

The Antari M-Series Stage Fogger are ideal for large concerts, movie production, fire training purpose and especially for touring applications, as well as any venue where ultimate performance, ease of use and dependability are specified. It is the most powerful single heater-block fog machine available on the market.

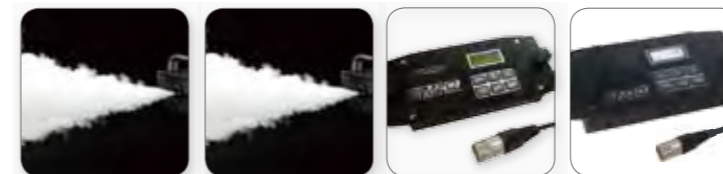

• M-5 Effect

• M-10 Effect

• M-20 Control Module

• M-30PRO Wireless Control Module

M-5 Fog Machine Specification

- » Power : AC100V/AC120V/AC230V/AC240V,50Hz-60Hz
- » Heater : 1,500 W
- » Output : 25,000 cu.ft / min
- » First Heat-up Time : 8 min
- » Tank Capacity : 10 liter
- » Fluid Consumption Rate : 6 min / liter (100% Output)
- » Remote Included : M-20 Control Module
- » Optional Remotes : M-30PRO Wireless Control Module
- » Optional Accessories : FM-5 Flight Case , M5-HB Hanging Bracket
- » Weight : 15 Kg
- » Dimensions (mm) : L 668 W 319 H 170
- » DMX : On board

M-10 Fog Machine Specification

- » Power : AC230V/AC240V,50Hz-60Hz
- » Heater : 3,000 W
- » Output : 50,000 cu.ft / min
- » First Heat-up Time : 13 min
- » Tank Capacity : 10 liter
- » Fluid Consumption Rate : 4 min / liter (100% Output)
- » Remote Included : M-20 Control Module
- » Optional Remotes : M-30PRO Wireless Control Module
- » Optional Accessories : FM-10 Flight Case
- » Weight : 21 Kg
- » Dimensions (mm) : L 690 W 319 H 192
- » DMX : On board
- » Wireless DMX is optional for both M-5 & M-10

Liquid

- » Recommended Antari FLR/FLG
- High quality and performance, environmental-friendly.
- Fog liquid with no oily residue and longer lifespan for the machines.

FAZER PRO



FLG-5
Heavy Fog Liquid

The X-PRO Series / X-310PRO Faze Machine

This versatile X-310PRO Fazer is the evolution of a fog machine and a haze machine. The Fazer has the best features of both machines without compromises. The X-310PRO boasts a fine, dry haze effect near perfection for lighting. The X-310PRO is equipped with a range of sophisticated features which include a high precision PCB design; aluminum cast heater, a silent heavy-duty pump and controllable twin fans. Precise fan control is achieved by 3 adjustable levels with DMX on-board. DMX connection can be worked by either 3 or 5 pin connector.

Silence is golden in some particular environment thus X-310PRO is equipped with the quietest pump allowing for virtually silent operation, making the machine ideal for use at noise-sensitive events. A perfect haze of fine particles is easily achieved with minimal residue, ensuring long-term reliability of those sensitive lighting equipments.

No doubt X-310PRO has become the machine of choice for stage and studio professionals worldwide.

X-310PRO Faze Machine Specification

- » Power : AC100V/AC120V/AC230V/AC240V,50Hz-60Hz
- » Heater : 1,000 W
- » Output : 3,500 cu.ft / min
- » First Heat-up Time : 10 min
- » Fluid Consumption Rate : 45 min / liter (100% Output)
120 min / liter (30% Output)
- » Tank Capacity : 2.4 liter
- » Low Fluid Indicator : Blue LED
- » Remote Included : X-10PRO Control Module
- » Optional Remotes : X-30PRO Wireless Control Module
- » Optional Accessories : FX-310 Flight Case
- » Weight : 18 Kg
- » Dimensions (mm) : L 635 W 275 H 281
- » DMX : On board
- » Wireless DMX is optional for X-310PRO 
- » DMX Channel Occupied : 2 Channels (one for fog output;
one for fan output)

X-10PRO Control Module

- » Cable Length : 2 M
- » Connector : 5 Pin XLR
- » Function : Timer with interval, duration and volume; set DMX address; continuous fogging; manual ON/OFF. (all above functions are displayed on a LCD screen; can be set precisely in seconds or percentage)

Liquid

- » Recommended Antari FLG
High quality and performance, environmental-friendly.
Fog liquid with no oily residue and longer lifespan for the machines.



• X-310PRO

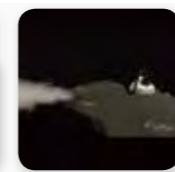

• X-310PRO Effect



• X-10PRO Control
Module



• FX-310 Flight Case

FLG-5
Heavy Fog LiquidFLR-5
Light Fog Liquid

The X-PRO Series / X-510PRO & X-515PRO Fog Machine

The Professional Eco-Friendly Fog Solution for High-Density fog with newly-designed on-board DMX software. Incorporating fine-tuned PCB layout, stability becomes standard for all X-PRO Series Fog Machine to enhance the unique mood of lighting.

This professional line of heavy-duty fog machine features the most advanced technology with a number of exceptional components that separate them from all other fog machines available.

Both X-510PRO and X-515PRO ensure only the purest, driest white fog is produced to the satisfaction of all demanding industry professionals. The electronic fluid level sensor stops operation in low-fluid situations offering complete protection to the pump and the heater. The X-PRO Series Foggers are the perfect solution for all intensive effect productions.

The entire X-PRO Series also caters to the transportability needs of the touring and rental markets with custom flightcases available for all X-PRO Series Fog Machine.

X-510PRO Fog Machine Specification

- » Power : AC100V/AC120V/AC230V/AC240V,50Hz-60Hz
- » Heater : 1,000 W
- » Output : 10,000 cu.ft / min
- » First Heat-up Time : 11 min
- » Fluid Consumption Rate : 17 min / liter (100% Output)
- » Tank Capacity : 2.8 liter
- » Remote Included : X-10PRO Control Module
- » Optional Remote : X-30PRO Wireless Control Module
- » Optional Accessories : FTA-1 Fog Hose Adaptor, FX-510 Flight Case
HB-10 Hanging Bracket
- » Weight : 11.5 Kg
- » Dimensions (mm) : L552 W230 H155
- » DMX : On board
- » Liquid Used : Antari FLR / FLG

X-515PRO Fog Machine Specification

- » Power : AC100V/AC120V/AC230V/AC240V,50Hz-60Hz
- » Heater : 1,500 W
- » Output : 20,000 cu.ft / min
- » First Heat-up Time : 8.5 min
- » Fluid Consumption Rate : 8.5 min / liter (100% Output)
- » Tank Capacity : 6 liter
- » Remote Included : X-10PRO Control Module
- » Optional Remote : X-30PRO Wireless Control Module
- » Optional Accessories : HB-10 Hanging Bracket and Drip Tray,
FTA-1 Fog Hose Adaptor for Connecting DNG,
FX-515 Flight Case
- » Weight : 13.2 Kg
- » Dimensions (mm) : L646 W240 H190
- » DMX : On board
- » Wireless DMX is optional for X-515PRO
- » Liquid Used : Antari FLR / FLG

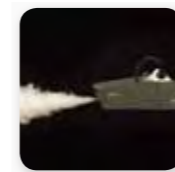

• X-510PRO Effect



• X-515PRO Effect

• X-10PRO Control
Module• FX-510 / FX-515
Flight Case

FLG-5
Heavy Fog LiquidFLR-5
Light Fog Liquid

Mobility and Portability Fog Machine Z-800II

Z-800II, a cutting-edge technology designed by Antari is aimed to meet the demands of mobility and portability. An ideal machine for easy operation that is perfect for smaller venues and DJs. The Z-800II, whether controlled via wireless, timer or in stand-alone mode, features rock-steady continuous output. Z-800II can undertake a fast warm-up time less than 100 seconds and produces a steady, constant fog as long as you need without any reheating time in between.

This machine encompasses all technical aspects with per excellence performance and workmanship design. With its high efficient power control system, it now allows the fogger to operate at low-level temperature resulting in 20% less electricity than its previous model.

Z-800II sets the standard in mobility/portability fog machine range presented by Antari. Apparently a user-friendly device and a remarkable fog machine perfect for clubs, discotheques and small venues.

Z-800II Fog Machine Specification

- » Power : AC100V/AC120V/AC230V/AC240V,50Hz-60Hz
- » Heater : 800 W
- » Output : 3,000 cu.ft / min
- » First Heat-up Time : 100 Sec
- » Tank Capacity : 0.8 liter
- » Fluid Consumption Rate : 60 min / 0.8 liter (100% Output)
- » Remote Included : Z-10 ON/OFF (Toggle Switch)
- » Optional Remotes : Z-40 Timer Remote , Z-50 Wireless Remote
- » Weight : 3.5 Kg
- » Dimensions (mm) : L 315 W 128 H 165.5

Z-10 Remote

- » Cable Length : 25 ft
- » Connector : 1/4 Stereo
- » Function : ON/OFF (Toggle Switch)

Z-40 Timer Remote (Optional)

- » Cable Length : 25 ft
- » Connector : 1/4 Stereo
- » Function : Timer with interval and duration; manual ON/OFF

Z-50 Wireless Remote (Optional)

- » Working Distance : Wireless, up to 50 M
- » Connector : 1/4 Stereo
- » Function : Wireless ON/OFF

Liquid

- » Recommended Antari FLR/FLG
- High quality and performance, environmental-friendly.
- Fog liquid with no oily residue and longer lifespan for the machines.

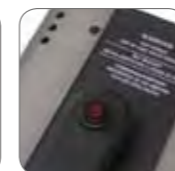

• Rear Panel

• Manual ON / OFF
Button

• Z-800II Effect



• Z-10 Remote

FLG-5
Heavy Fog LiquidFLR-5
Light Fog Liquid

Z-1020 Two-Way Fog Machine

Z-1020, the most powerful DMX-controlled vertical pure fog machine which stands differently from the other Z-Series. Its design is for special purposes and applications which you can't find in any fog machines available. It uses mirror-piping heater technology that supports advance features and high-throughout burst mode with its extreme low energy consumption.

The Z-1020 can be positioned on the ground to fog upward to have a column of fog effect or can be mounted on the wall to easily blend the surroundings with atmospheric effect. Or else can be used to fog in upright position by carrying the handle like ordinary fog machine. Other features include DMX on-board, built-in electronic low fluid detector. Light weight, sleek and compact design, easy installation and maintenance.

Z-1020 is perfect for theatrical and studio application, large halls, concerts, DJ touring and clubs. Custom flight cases are also an optional choice for 2 units of Z-1020.

Z-1020 Two-Way Fog Machine Specification

- » Power : AC100V/AC120V/AC230V/AC240V,50Hz-60Hz
- » Heater : 1,000 W
- » Output : 10,000 cu.ft / min
- » First Heat-up Time : 11 min
- » Tank Capacity : 2.4 liter
- » Fluid Consumption Rate : 11 min / liter (100% Output)
- » Remote Included : Z-10 ON/OFF (Toggle Switch)
- » Optional Remotes : Z-40 Timer Remote , Z-50 Wireless Remote
- » Optional Accessories : FZ-1020 Flight Case
2 units of Z-1020 can be put into 1 flight case
- » Weight : 9.8 Kg
- » Dimensions (mm) : L 370 W 295 H 135
- » DMX : On board

Z-10 Remote

- » Cable Length : 25 ft
- » Connector : 1/4 Stereo
- » Function : ON/OFF (Toggle Switch)

FZ-1020 Flight Case

- » Dimensions (mm) : L 530 W 390 H 438
- » Weight : 9.5 Kg
- » Compatible With : Z-1020 x 2 units

Liquid

- » Recommended Antari FLR/FLG
High quality and performance, environmental-friendly.
Fog liquid with no oily residue and longer lifespan for the machines.



Control Panel

Z-1020 Effect
Horizontal OutputZ-1020 Effect
Vertical Output

FZ-1020 Flightcase

Z-Series II
Ideal Fog



FLG-5 Heavy Fog Liquid
FLR-5 Light Fog Liquid

Z-1000II & Z-1200II Fog Machine

Z-1000II and Z-1200II dominate the entry-level of Z-Series II Fog Machine for high performance output necessary to scale up the machines' efficiency. It is equipped with ECO thermal control system and patented UNICORE heater technology where the heater core can be easily draw-out from the heater block ensuring quick and easy cleaning.

The heater element is like a jet air stream that can deliver a powerful fog in order to create the very best atmospheric effect. (perfect for mid-air smoke as well) In addition, it is armed with on-board DMX to work with club lighting directors, installers, planners as well as DJ' s who need more fog and control.

Z-1000II and Z-1200II come with high-quality pump and electronic low-fluid detector also known as Thermal Cut-Off (TCO), which automatically reactivates and shuts down the pump power when the fluid level is low and depleted. Other features include standard hanging bracket to facilitate in any installations or on the road from venue to venue.

Z-1000II Fog Machine Specification

- » Power : AC100V/AC120V/AC230V/AC240V,50Hz-60Hz
- » Heater : 1,000 W
- » Output : 10,000 cu.ft / min
- » First Heat-up Time : 5.5 min
- » Tank Capacity : 1.7 liter
- » Fluid Consumption Rate : 18 min / liter (100% Output)
- » Remote Included : Z-10 ON/OFF (Toggle Switch)
- » Optional Remotes : Z-40 Timer Remote , Z-50 Wireless Remote
- » Accessory Include : Hanging Bracket
- » Weight : 6.6 Kg
- » Dimensions (mm) : L 433 W 198 H 151
- » DMX : On board

Z-1200II Fog Machine Specification

- » Power : AC100V/AC120V/AC230V/AC240V,50Hz-60Hz
- » Heater : 1,200 W
- » Output : 18,000 cu.ft / min
- » First Heat-up Time : 9 min
- » Tank Capacity : 2.5 liter
- » Fluid Consumption Rate : 15 min / liter (100% Output)
- » Remote Included : Z-8 Timer Remote
- » Optional Remotes : Z-9 Wireless Remote
- » Accessory Include : Hanging Bracket
- » Weight : 10.9 Kg
- » Dimensions (mm) : L 458 W 243 H 177
- » DMX : On board

Liquid

- » Recommended Antari FLR/FLG
High quality and performance, environmental-friendly.
Fog liquid with no oily residue and longer lifespan for the machines.



• Z-1000II Effect

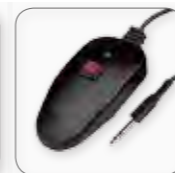

• Z-10 Remote

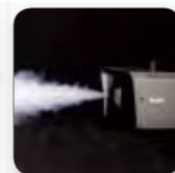

• Z-1200II Effect

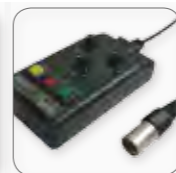

• Z-8 Timer Remote



FLG-5 Heavy Fog Liquid FLR-5 Light Fog Liquid

Make Your Event Dynamic / Z-1500II & Z-3000II Fog Machine

Antari proposes to you the Z-1500II and Z-3000II, the rigorous research and development resulting stability, durability, and reliability. When it comes to ultimate performance and precision control, the Z-1500II & Z-3000II will suit virtually any applications.

These fog machine provide significant advantages in a wide array of applications where volume of fog output is critical. Around 25% electricity is saved due to high efficient power control system allowing the fogger to operate at low-level temperature.

An electronic low fluid detector is also installed which automatically weakens pump power and stops pumping when running-out of fluid. They are fully controllable via Z-20 LCD control module supplied allowing the operator to set the volume control and timing precisely to the exact percentage from 1% to 100% output. DMX connection can be worked by either 3 or 5 pin connector.

These machines are Antari' s proud innovation; they are dedicated to most demanding professionals. Ideal for very large venues, outdoor event, movie

Z-1500II Fog Machine Specification

- » Power : AC100V/AC120V/AC230V/AC240V,50Hz-60Hz
- » Heater : 1,500 W
- » Output : 20,000 cu.ft / min
- » First Heat-up Time : 8.5 min
- » Tank Capacity : 6 liter
- » Fluid Consumption Rate : 9 min / liter (100% Output)
- » Remote Included : Z-20 Control Module
- » Optional Remotes : Z-30PRO Wireless Control Module
- » Weight : 14 Kg
- » Dimensions (mm) : L 688 W 285 H 188
- » DMX : On board
- » Liquid Used : Antari FLR / FLG

Z-3000II Fog Machine Specification

- » Power : AC230V/AC240V,50Hz-60Hz
- » Heater : 3,000 W
- » Output : 40,000 cu.ft / min
- » First Heat-up Time : 12 min
- » Tank Capacity : 6 liter
- » Fluid Consumption Rate : 5 min / liter (100% Output)
- » Remote Included : Z-20 Control Module
- » Optional Remotes : Z-30PRO Wireless Control Module
- » Weight : 19.9 Kg
- » Dimensions (mm) : L 735 W 310 H 192
- » DMX : On board
- » Liquid Used : Antari FLR / FLG

Z-20 Control Module

- » Cable Length : 2 M
- » Connector : 5 Pin XLR
- » Function : Timer with interval, duration and volume; set DMX address; continuous fogging; manual ON/OFF.



• Z-1500II Effect



• Z-3000II Effect



• Z-20 Control Module



• Z-30PRO Wireless Control Module (Optional)

Z³⁰⁰ Series[®]



FLG-5
Heavy Fog Liquid

Z-300II Faze Machine

The Z-300II Fazer is designed to bring out the best in lighting equipment by silently producing perfect, translucent haze.

This revolutionary machine uses regular water-based fog liquid to produce an effect that is identical to hazers. The Z-300II does not use an air compressor as it adopts heater technology.

Itself boasts constant output and variable volume control silently. Certainly a fine choice ideal for uses in events that are noise-sensitive.

Z-300II Faze Machine Specification

- » Power : AC100V/AC120V/AC230V/AC240V,50Hz-60Hz
- » Heater : 700 W
- » Output : 2,000 cu.ft / min
- » First Heat-up Time : 4.0 min
- » Tank Capacity : 1.3 liter
- » Fluid Consumption Rate : 1 hr / liter (100% Output)
- » Remote Included : Z-6 Timer Remote
- » Weight : 9 Kg
- » Dimensions (mm) : L 525 W 207 H 173

Z-6 Timer Remote

- » Cable Length : 25 ft
- » Connector : 5 Pin DIN
- » Function : Timer with volume and duration;
Continuous hazing; manual ON/OFF

Liquid

- » Recommended Antari FLG Heavy Fog Liquid.
High quality and performance, environmental-friendly.
Fog liquid with no oily residue and longer lifespan for the machines.



• Rear Panel



• Z-6 Timer Remote



• Z-300II Effect



FLM-05
M-1 Fog Liquid



• M-1 kit

M-1 Mobile Fog Machine

The M-1 Mobile Fog Machine is developed especially for photographers to use on location and have found work in theatrical and cinematic applications.

This Mobile fogger is perfect for situations where a touch of fog is required in remote or unexpected places. Because of its dimensions and weight (about 2 kg) this mobile fogger can be discretely placed on props, inside sets, or held on hand.

As implied by its name, the mobile fogger's main characteristic is its mobility. The unit operates on a compact 12V DC rechargeable battery and is very easy to carry and operate without any warming-up time.

Or else, the M-1 can also operate with corded dummy battery. To increase the machine's versatility, timer and wireless remotes are available as optional.



• M-1 Effect



• Battery & Charger



• DCP-12 Power Adaptor /
Dummy Battery (Optional)

M-1 Mobile Fog Machine Specification

- » Output : 300 cu.ft / min
- » Power Consumption : 75 W
- » Tank Capacity : 110 c.c.
- » Battery : DC 12V / 2.3Ah
- » Consumption : 2 c.c. / min
- » Optional Remotes : MCT-1 Timer Remote,
MCR-1 Wireless Remote
- » Optional Accessories : DCP-12 Power Adaptor / Dummy Battery
- » Weight : 6 Kg , Whole M-1 Kit
- » Dimensions (mm) : L 227 W 66 H 81

* M-1 kit includes a M-1 fog machine, a case, a rechargeable battery, a charger, and a bottle of 500c.c. FLM-05 M-1 fog liquid.

MCR-1 Wireless Remote (Optional)

- » Working Distance : Wireless, up to 50 M
- » Connector : 4 Pin S Terminal
- » Function : Wireless ON/OFF

Liquid

- » Use Antari FLM-05 M1 Fog Liquid Only.
The FLM-05 is the Fog liquid especially tailored for M-1 Fogger, with best quality no artificial colors are added and can generates the best, pure, and clean fog when goes with the M-1 model!



LCU-1 Liquid Control Unit

The LCU-1 Liquid Control Unit is the ultimate club system for club installations. The system features a separate, ground-based liquid supply that can be stored wherever is most convenient for the operator.

This means no more climbing ladders to fill the empty liquid containers night after night. Fog liquid can be automatically pumped right out of Antari fog liquid containers if desired. Setup is as simple as making the connections from the LCU-1 to the machines as shown in the diagram.

The casing of the machines are designed to fit easily into conventional trussing. With DMX on-board, the machines and the LCU-1 can all be set to the same channel for straightforward operation.

In addition, a separate DMX address is given which provides greater control over the effect produced and in this setup, please make sure that each of the machine channels are paired with the LCU-1's DMX channel.

This way, if the first Z-1200II is activated, the LCU-1 will pump liquid to that machine, when the 2nd Z-1200II is activated, the LCU-1 will pump again and so on. Hence, LCU-1 will not pump liquid unless the LCU-1's DMX channel is selected and it has satisfied user's requirement of full control on its performance.

LCU-1 has given club operators what they need: complete control and ease of use. And no more ladders to climb!

LCU-1 Liquid Control Unit Specification

- » Power : AC100V/AC120V/AC230V/AC240V,50Hz-60Hz
- » Remote Included : depends on machine used
- » Optional Remotes : Z-8 Timer Remote
- » Weight : 2.7 Kg
- » Dimensions (mm) : L 215 W 193 H 105
- » Compatible With : Z-1200II, ICE-101, S-100II, S-200
- » Function : DMX On-board

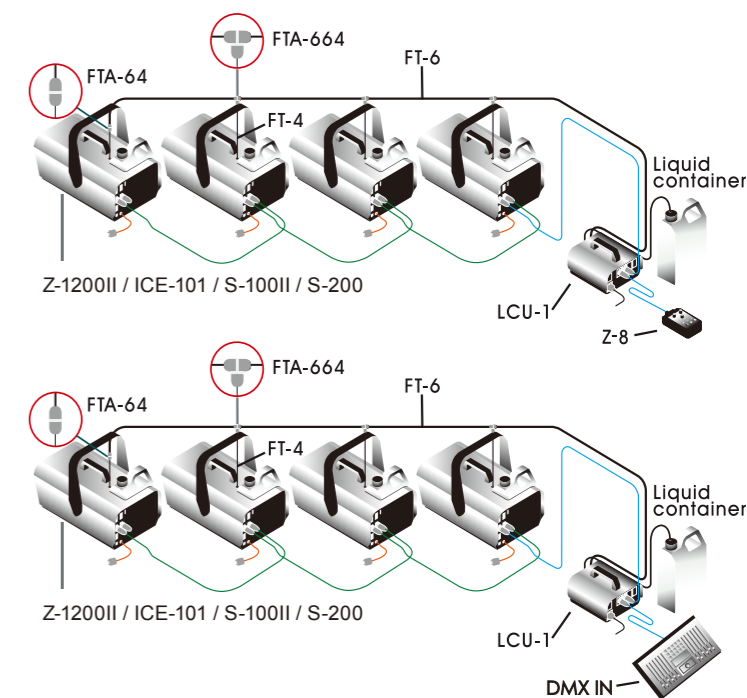



SL-5
Snow / Foam Liquid

S-120 Foam Machine

Antari S-120 foam machine is reliable, environmentally and user-friendly. It produces clear and bubbly foam suitable for a wide variety of applications.

S-120 can be easily operated by a beginner who is not a pro user in machines. Also its output is continuously regulated when using Antari dealer recommended SL-5 liquid. The foam produced is safe, clean and odorless.

In fact, Antari has designed this foam machine with a smaller size that is suitable for small stage effects and parties. As an increasing numbers of people who prefer to celebrate their parties at home, a small portable and easy-to-operate machine would always be an amusing supporting cast to include.

S-120 Foam Machine Specification

- » Power : AC100V/AC120V/AC230V/AC240V,50Hz-60Hz
- » Power Consumption : 600 W
- » Output : 320ml / min
- » Tank Capacity : 5 liters
- » Weight : 12 Kg
- » Dimensions (mm) : L 600 W 260 H 300
- » Function : On/Off Only

Liquid

- » Optimized for use with Antari Snow Machines
- SL-5 : water-based snow liquid for accumulated snowflake effect



• Rear Panel



• S-120 Effect



Antari
HAZE MACHINE

*Antari's Haze machines produce safe,
clean and virtually invisible haze, which enhances
the beams from projected lighting equipment.*



HZL-1
Haze Liquid

HZ-100 Haze Machine

This durable, compact size HZ-100 conveniently lends itself to stage, concert and movie work where ease of operation is desired.

The HZ-100 comes equipped with an efficient, maintenance-free air compressor where no warming time required before operation; just turn on and you will have the beautiful optical translucent haze without hassle.

On the other hand, you can simply attach the optional HC-1 Timer Controller to the HZ-100 and adjusts the timer's interval and duration settings at ease.



• HC-1 Timer
Remote (Optional)



• HCR-1 Wireless
Remote (Optional)



• HZ-100 Effect

HZ-100 Haze Machine Specification

- » Power : AC100V/AC120V/AC230V/AC240V,50Hz-60Hz
- » Output : 1,000 cu.ft / min
- » Tank Capacity : 2.5 liter
- » Fluid Consumption Rate : 25 hr / liter
- » Optional Remotes : HC-1 Timer Remote
HCR-1 Wireless Remote
- » Air Pressure : 30 Psi
- » Weight : 12 Kg
- » Dimensions (mm) : L 484 W 250 H 236
- » DMX : None

HC-1 Timer Remote (Optional)

- » Cable Length : 25 ft
- » Connector : 1/4 Stereo
- » Function : Timer with interval and duration; manual ON/OFF

HCR-1 Wireless Remote (Optional)

- » Working Distance : Wireless, up to 50M
- » Connector : 1/4 Stereo
- » Function : Wireless ON/OFF

Liquid

- » Optimized for use with all Antari Haze machines.
This oil-based HZL-1 produces translucent haze with long hanging time.

HZ-400



HZL-1
Haze Liquid

HZ-400 Professional Haze Machine

The HZ-400 is equipped with an internal, maintenance-free air compressor, a sophisticated haze transfer mechanism, and a specially designed liquid tank. The HZ-400 is equipped with two haze nozzles capable of producing virtually invisible large volume of haze output.

The fine translucence and non-stop output produced by HZ-400 makes more remarkable by the fact that with this hazer there are no temperature controls, hot air and warm-up times during operation.

Its internal compressor is extremely powerful, quiet and very efficient. With an added on-board DMX which provides users to control the unit by any DMX 512.

HZ-400 Professional Haze machine is the elegant combination between the ultimate haze quality from high capacity, low fluid consumption and silent operation demanded by professionals.



• HZ-400 Rear Panel



• HC-1 Timer Remote



• HCR-1 Wireless Remote (Optional)

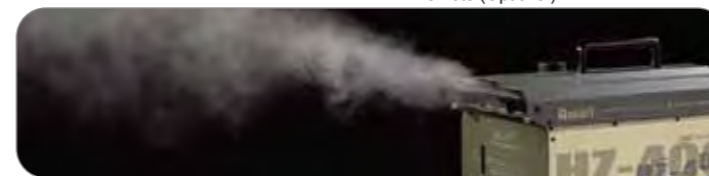

• HZ-400 Effect

HZ-400 Haze Machine Specification

- » Power : AC100V/AC120V/AC230V/AC240V,50Hz-60Hz
- » Output : 2,800 cu.ft / min
- » Tank Capacity : 2.5 liter
- » Fluid Consumption Rate : 16 hr / liter
- » Remote Included : HC-1 Timer Remote
- » Optional Remote : HCR-1 Wireless Remote
- » Air Pressure : 100 Psi
- » Weight : 18.5 Kg
- » Dimensions (mm) : L 500 W 320 H 246
- » DMX : On board

HC-1 Timer Remote

- » Cable Length : 25 ft
- » Connector : 1/4 Stereo
- » Function : Timer with interval and duration; manual ON/OFF

HCR-1 Wireless Remote (Optional)

- » Working Distance : Wireless, up to 50M
- » Connector : 1/4 Stereo
- » Function : Wireless ON/OFF

Liquid

- » Optimized for use with all Antari Haze machines.
- This oil-based HZL-1 produces translucent haze with long hanging time.

Hazer Technology
HZ-500



HZL-1
Haze Liquid

HZ-500 Haze Machine

Antari is proud to unveil the innovative Hazer with passion, HZ-500, to entertainment industry. This groundbreaking masterpiece created by Antari R&D team is invested with enormous experience in studying and designing haze machines after years of hard work.

Therefore, the performance of HZ-500 is second to none and better than any other hazers on stage. It can work perfectly with laser beam, lighting and bring the best atmospheric effects to all events.

HZ-500 is definitely the best choice for those stage designers, performers, and audiences who are sensitive to surrounding settings. Last but not the least, the extraordinary low haze liquid consumption rate makes HZ-500 more energy-efficient and more environmental-friendly. silent operation demanded by professionals.

HZ-500 Haze Machine Specification

- » Power : AC100V/AC120V/AC230V/AC240V,50Hz-60Hz
- » Output : 3,000 cu.ft. / min
- » Tank Capacity : 2.5 liter
- » Fluid Consumption Rate : 24 hr / liter
- » Control : LCD screen , Timer mode
- » Compact Flight Case Included
- » Air Pressure : 100 Psi
- » Weight : 31.5 Kg
- » Dimension (mm) : L 490 W 351 H 338
- » DMX : On board

Liquid

- » Optimized for use with all Antari Haze machines.
- This oil-based HZL-1 produces translucent haze with long hanging time.



• HZ-500 Effect



• HZ-500 Haze Machine



• Fluid Level Indicator



• HZ-500 Control Panel



Antari
SNOW MACHINE

*Hush and you might hear the snow fall,
but you won't hear the Antari Snow Machine.*

SL-5A
Snow Liquid PremiumSL-5
Snow / Foam Liquid

S-100II & S-200 Snow Machine

Antari continues to excel in the snow effect range built to the same stringent standard as our fog machines. There are three models available for your choice: S-100II, S-200 and SW-250.

The S-100II is a robust, high pressure, large output snow machine that produces abundant amounts of snow that are capable of blowing considerable distances. The durable motor is enclosed in rubber cushions within the case for high output and low vibration.

The S-200, on the other hand, is the Silent Snow Machine designed to compliment all your scenes where silence and mood are golden; With just **63dB** noise level similar to people whisper lightly. Great break-through and progress has invested in this ANTARI S-200 in terms of its noise level and the formation of snowflake. Output of the snowflake is adjustable which enables producing different volume of snow output from a light snowfall to a heavy flurry.

Both S-100II and silent S-200 have standard DMX on-board including SC-2 volume control remote. Hanging bracket comes standard for ease of trussing and installation. Both models are light and portable machine which are perfect for club effects, movie sets and stage settings where quiet scenes and lifelike snow effect are demanded.

Let the snow fall all season round!



• S-100II Effect



• S-200 Effect

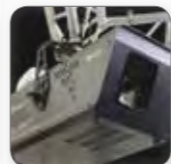

• S-200



• SC-2 Remote

S-100 II Snow Machine Specification

- » Power : AC100V/AC120V/AC230V/AC240V,50Hz-60Hz
- » Power Consumption : 600 W (Min Output) , 1130 W (Max Output)
- » Output : 140 ml / min
- » Tank Capacity : 5 liter
- » Fluid Consumption Rate : 10 min / liter (100% Output)
- » Remote Included : SC-2 Volume Remote
- » Accessory Include : Hanging Bracket
- » Weight : 10 Kg
- » Dimensions (mm) : L 505 W 276 H 222
- » DMX : On board

S-200 Silent Snow Machine Specification

- » Power : AC100V/AC120V/AC230V/AC240V,50Hz-60Hz
- » Power Consumption : 600 W (Min Output) , 1130 W (Max Output)
- » Output : 140 ml / min
- » Tank Capacity : 5 liter
- » Fluid Consumption Rate : 10 min / liter (100% Output)
- » Remote Included : SC-2 Volume Remote
- » Accessory Include : Hanging Bracket
- » Weight : 12 Kg
- » Dimensions (mm) : L 525 W 276 H 228
- » DMX : On board

SC-2 Remote

- » Cable Length : 25 ft
- » Connector : 4 Pin XLR
- » Function : ON/OFF and volume

Liquid

- » Optimized for use with Antari Snow Machines
- SL-5 : Standard snow liquid for accumulated snowflake effect
- SL-5A : Premium snow liquid for fast disappearing



Antari
BUBBLE MACHINE

High Output Bubble Machine brings you fun all the time!



BL-5
Bubble Liquid

B-100 / B-100X Bubble Machine

This handy party gizmo is equipped with the "Double Bubble Wheel" designed to produce a solid, plentiful amount of bubbles continuously.

The B-100's mouth directs a high output of bubbles up into the air while simultaneously recycling liquid and eliminating dripping. Easy refills and the included hanging bracket makes the B-100 very user-friendly. Without doubt, the B-100 is sure to make any celebration a memorable one.

Note: the B-100X contains a control board allowing the bubble machine to use the wireless and timer remote controls. The B-100, without this board, cannot use these remote controls. The two versions are identical in all other aspects.



• Z-10 Remote
(Optional)



• BCT-1 Timer
Remote (Optional)



• BCR-1 Wireless
Remote (Optional)



• B-100 Effect

B-100 , B-100X Bubble Machine Specification

- » Power : AC100V/AC120V/AC230V/AC240V,50Hz-60Hz
- » Power Consumption : 25 W
- » Tank Capacity : 1 liter
- » Fluid Consumption Rate : 2 hr / liter
- » Optional Remotes for B-100X Only : Z-10 ON/OFF Remote ,
BCT-1 Timer Remote ,
BCR-1 Wireless Remote
- » Weight : 4.2 Kg
- » Dimensions (mm) : L 340 W 170 H 172

Z-10 Remote (Optional)

- » Cable Length : 25 ft
- » Connector : 1/4 Stereo
- » Function : ON/OFF (Toggle Switch)

BCT-1 Timer Remote (Optional)

- » Cable Length : 25 ft
- » Connector : 1/4 Stereo
- » Function : Timer with interval and duration; manual ON/OFF

BCR-1 Wireless Remote (Optional)

- » Working Distance : Wireless, up to 50 M
- » Connector : 1/4 Stereo
- » Function : Wireless ON/OFF

Liquid

- » Optimized for use with Antari Bubble Machines
- BL-5 : Also friendly to our environment and to human contact bubble liquid that creates vivid bubbles for any occasions.



BL-5
Bubble Liquid

B-200 High Output Bubble Machine

To say the B-200 is a high output bubble machine is too modest. It features four "Double Bubble Wheels" which generate a massive, continuous torrent of bubbles.

The set of 3 fans at the back of the unit spread the bubbles far and wide. Designed with lighting designers, large clubs and theatrical productions in mind, this bubble machine has DMX onboard.

This provides for central control on B-200's bubble generation. The machine can also operate with / without optional timer and wireless remote controls.

With its large fluid reservoir, the B-200 will pack the venue with bubbles as long as the party lasts!



• BCT-1 Timer Remote (Optional)



• BCR-1 Wireless Remote (Optional)



• B-200 Effect

B-200 High Output Bubble Machine Specification

- » Power : AC100V/AC120V/AC230V/AC240V,50Hz-60Hz
- » Power Consumption : 100 W
- » Tank Capacity : 2 liter
- » Fluid Consumption Rate : 20 min / liter
- » Optional Remotes : BCR-1 Wireless Remote, BCT-1 Timer Remote
- » Weight : 11 Kg
- » Dimensions (mm) : L 421 W 250 H 212.5
- » DMX : On board

BCT-1 Timer Remote (Optional)

- » Cable Length : 25 ft
- » Connector : 1/4 Stereo
- » Function : Timer with interval and duration; manual ON/OFF

BCR-1 Wireless Remote (Optional)

- » Working Distance : Wireless, up to 50 M
- » Connector : 1/4 Stereo
- » Function : Wireless ON/OFF

Liquid

- » Optimized for use with Antari Bubble Machines
- BL-5 : Also friendly to our environment and to human contact bubble liquid that creates vivid bubbles for any occasions.



Antari
LOW FOG MACHINE

*“My little spirit, see . Sits in a foggy cloud, and stays for me.”
– William Shakespeare*



FLR-5
Light Fog Liquid

ICE-101 ICE Fog Machine

ICE-101 Ice fog machine, as its name suggests, produces beautiful floor-hugging dry ice fog effect by simply adding regular ice cubes. Without the inconvenience of dry ice or the potential health hazards caused by dry ice's heavily CO₂ smoke, this ICE Fog machine is expected to be environmentally friendly. A high power 1000W fog machine inside creates amounts of fog which is chilled to create a low lying ground hugging fog effect.

10kg of ice cubes placed in the ice chamber can be stored up to 8 hours & up to 1 hour of continuous operation. Full DMX on-board means 100% control and the drainage pump can be activated manually or set to automatic for optimum convenience.

You will never want to go back to dry ice machine again because this unit is very easy & safe to operate as it is the most convenient way to create ankle-deep fog for many applications.



• ICE-101 Rear Panel



• Z-8 Timer Remote



• ICE-101 Ice Chamber
with Ice Cubes

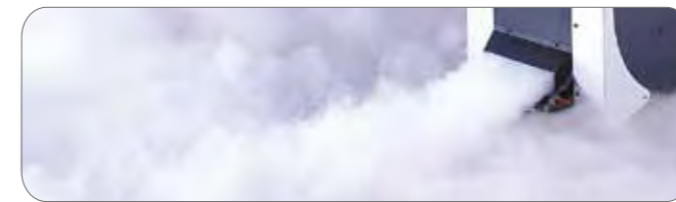

• ICE-101 Effect

ICE-101 ICE Fog Machine Specification

- » Power : AC100V/AC120V/AC230V/AC240V,50Hz-60Hz
- » Heater : 1,000 W
- » Output : 10,000 cu.ft / min
- » First Heat-up Time : 4.5 min
- » Tank Capacity : 2.5 liter
- » Fluid Consumption Rate : 40 min / liter
- » Remote Included : Z-8 Timer Remote
- » Weight : 24.4 Kg
- » Dimensions (mm) : L 660 W 355 H 359
- » DMX : On board

Z8 Timer Remote

- » Cable Length : 25 ft
- » Connector : 4 Pin XLR
- » Function : Timer with interval, duration and volume;
continuous fogging; manual ON / OFF

Liquid

- » Use only FLR (Light Fog Liquid) for best ICE-101 effects
- High quality and performance, environmental-friendly
- 100% Safe to lie in & breathe in

* **Note:** For best low fog effect, use Antari FLR fog liquid Only.



FLR-5
Light Fog Liquid

DNG-100 Fog Cooler

The DNG-100 converts normal fog from any fog machine (suggested models below) into a floor-hugging cloud of dense, white fog that's almost virtually similar to the dry ice effect. This is achieved by cooling the temperature of the fog to the point where it falls to the ground. The DNG-100 is easy to operate as there are no external controls on the machine. Simply plug the unit IN and place the fog conducting hose from the output of any fog machine to the input of the DNG-100.

The unit is fully operational upon being plugged IN. Note that the volume of fog produced is controlled by the fog machine that the DNG-100 is attached to.

DNG-100 Fog Cooler Specification

| | | |
|------------------------------------|-----------------------------------------------------------------|-----------------------|
| » Power : | AC 100-120V / 50-60Hz | AC 220-240V / 50-60Hz |
| » Power Consumption (Compressor) : | 750 W | 600 W |
| » Refrigerant : | R-404A, 1.75LB | R-404A, 1.75LB |
| » Rated Current : | 6.7A | 3.2A |
| » Start Current : | 61A | 21 A |
| » Accessories Included : | FT-10, FTA-10, FTA-11, FTA-12 | |
| » Optional Accessories : | FTA-1/2A/3 | |
| » Weight : | 72 Kg | |
| » Dimensions (mm) : | L 750 W 607 H 347 | |
| » Suggested Models : | X-515PRO, Z-1200II, Z-1500II, Z-3000II, M-5, M-10, W-515, W-530 | |

Two implementations of the DNG-100:

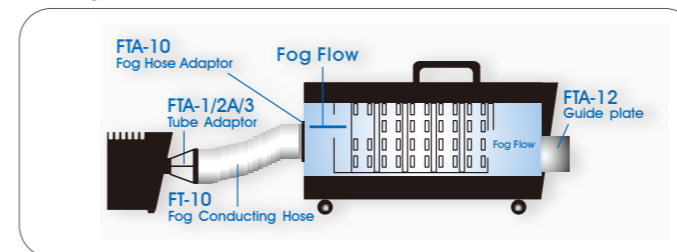

1. A fog conducting hose (FT-10) is attached to a fog machine's output nozzle via an adaptor (FTA-1/2A/3) and then connected to the FTA-10 adaptor attached to the DNG-100's intake. The fog flows efficiently from the fog machine through the DNG-100, and is directed downwards by the guide plate (FTA-12).

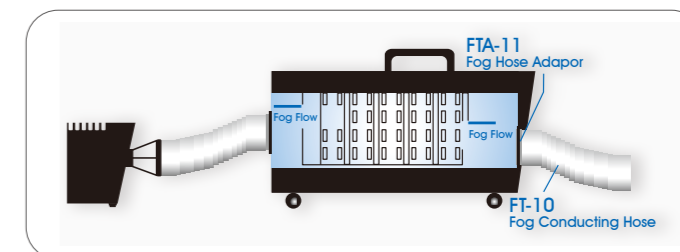

2. For strategic placement of low-lying fog, substitute the guide plate with a fog conducting hose that attaches to the front of the DNG-100 via an adaptor (FTA-11). This configuration allows the DNG-100's output to be guided to a desired area without being affected by air currents generated by movement, wind, fans or air conditioners.

* Note: For best low fog effect, use Antari FLR fog liquid Only.

DNG-200 LOW FOG GENERATOR



FLR-5
Light Fog Liquid



• DNG-200



• D-20 Control Module



• DNG-200 Effect



• FDNG-200 Flightcase
(Optional)

DNG-200 Low Fog Generator

The DNG-200 Low Fog Generator is the complete ground fog effect solution from a fully self-compacted unit with wheels and handles to stand against tough transport. With today's rising demand & awareness for environmental and health concern, the effects produced is virtually indistinguishable from that is created by dry ice.

Distinctively from other products currently on the market, it creates low fog straight from machine's nozzle. This makes it far more efficient and convenient without any hassles of CO₂ installations and other attachments.

It is operator-friendly as there are no external controls to the machine. Simply plug the unit and place the 3M fog conducting hose (for remote dispersion) and operate it like a normal fog machine.

Main Features:

1. No CO₂ is used. It's completely safe to human health and environment-friendly.
2. Powerful compressor offers continuous low fog output.
3. Efficient heat exchanger gives Antari DNG-200 capability to generate massive output and makes it the best of the category.
4. Strong wheels and optional flight case allow the unit to be moved with ease and ideal for tours.
5. Compare to the other similar low fog machines (using refrigerator, no CO₂, not dry ice), the low fog produced by Antari DNG-200 is relatively drier.

DNG-200 Low Fog Generator Specification

| | | |
|------------------------------------|--------------------------------------------------------------------------------------------------|-----------------------------|
| » Power : | AC 100-120V / 50-60Hz | AC 220-240V / 50-60Hz |
| » Power Consumption (Compressor) : | 750 W | 600 W |
| » Refrigerant : | R-404A, 1.75LB | R-404A, 1.75LB |
| » Rated Current : | 6.7A | 3.2A |
| » Start Current : | 61 A | 21 A |
| » Heater : | 1450W | 2500W |
| » Output : | 12,000 cu.ft / min | 12,000 cu.ft / min |
| » First Heat-Up Time : | 24 min | 12 min |
| » Tank Capacity : | 10 liter | 10 liter |
| » Fluid Consumption Rate : | 11 min/ liter (High output) | 11 min/ liter (High output) |
| » Remote Included : | D-20 Control Module | |
| » Accessory Included : | 3M Fog Conducting Hose | |
| » Optional Accessory : | FDNG-200 Flight Case | |
| » Weight : | 120 Kg | |
| » Dimensions (mm) : | L 780 W 608 H 686 | |
| » DMX : | On board | |
| » Additional information : | Self Contained Unit - No CO ₂ / Dry Ice Required Floor-Mount installations (4 wheels) | |

D-20 Control Module

- » Cable Length: 2 M
- » Connector: 5 Pin XLR
- » Function: Timer with interval, duration and volume; 4 Volume output choices (with non-stop fogging); Set DMX addresses; manual ON/OFF. (All above functions are displayed on a LCD screen & can be set precisely in seconds or percentage)

Liquid

- » Use only FLR (Light Fog Liquid) for best DNG-200 effects High quality and performance, environmental-friendly 100% Safe to lie in & breathe in.

* Note: For best low fog effect, use Antari FLR fog liquid Only.

ANTARI FAN
AF-5



AF-5 & AF-5R Special Effects Fan

AF-5, Antari's very first special effects fan.

3 sections fan speeds can fulfill different wind effects requests. It also can work with fog, haze, snow, bubble machines to bring special effects to higher and farther places.

Furthermore, on-board DMX control gives the fan extra intelligence.



• AF-5 With AF-5-HB Hanging Bracket (Optional)

AF-5 Special Effects Fan Specification

- » Power : AC 100~120V, 50/60HZ or AC 220~240V, 50/60HZ
- » Horsepower : 1 HP
- » Dimension (mm) : L 558 W 465 H 578
- » Dimension of Vent (mm) : 454 x 153
- » Weight : 17.5 Kg
- » Material of Housing : Plastic (Polypropylene)
- » 3 sections fan speed
- » Optional Remotes : W-1 Wireless Transmitter
- » Optional Accessory : AF-5-HB Hanging Bracket
- » DMX : On board
- » Adjustable Wind Angle : Horizontal, 45 degree, Vertical

AF-5R Special Effects Fan Specification

- » Remote Included : W-1 Wireless Transmitter

AF-5-HB (Optional)

- » Hanging Bracket For AF-5

W-1 Wireless Radio Transmitter (Optional)

- » Working Distance : Wireless , up to 50 M
- » Function : Wireless ON/OFF



• DMX & Wireless Module

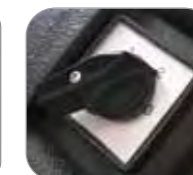

• Fan Speed Control



• W-1 Wireless Transmitter (Optional)



ANTARI LIQUID

Antari Fog liquids are optimized for use with all Antari fog machines and are suitable for most models of foggers. They are all water-based composition that leaves no oily residue. All of the liquid are odorless, non-irritating, non-toxic, and non-flammable. They preserve the longevity of your machines.

Our Material Safety Data Sheets (MSDS) and safety reports from SGS are complied by an independent laboratory for strictest tests.

The Antari fog liquid are eco-friendly to our environment and to human contact.

Antari Fog liquid comes in 2 varieties

FLR Light Fog Liquid (red color) produces fog which disappears in the air faster.
FLG Heavy Fog Liquid (green color) produces fog which has a longer lasting time.

They are available in either 1, 4, 5, 6 and 20 liters.

FLR: FLR-1, FLR-4, FLR-5, FLR-6, FLR-20

FLG: FLG-1, FLG-4, FLG-5, FLG-6, FLG-20

*the number -1, -4, -5, -6, -20 indicates the volume in liters.

The choice of fog liquid will depend on which Antari machine is used and also the density of fog you look for.



Haze Liquid

- » HZL-1: Specially composed haze liquid, HZL-1 is a non-toxic solution that produces a pure, translucent haze with an extremely long hanging time and low moisture content. Colorless, odorless and non-flammable, HZL-1 leaves no residue or contamination and complies with the strictest health and safety regulations.
- » HZL-1: Haze Liquid (1 liter)
- » HZL-5: Haze Liquid (5 liter)
- » Its composition will increase machine's lifespan for HZ-100 / 350 / 400 / 500.



Bubble Liquid

Designed for use in the Bubble Machines. Antari Bubble Liquid is a water-based composition that creates vivid, transparent bubbles. The liquid is colorless, odorless and non-flammable. The Antari bubble liquid is available in either one or five liter containers.

- » BL-1: Bubble Liquid (1 liter)
- » BL-5: Bubble Liquid (5 liter)



Snow Liquid

- » SL-5 : Designed for use in either Snow Machine or the S-120 Foam Machine. SL-5 Snow liquid is a water-based formula that is safe, non-toxic and 100% biodegradable. S-120 Foam Machine can only work with SL-5.
- » SL-5A : Premium Snow liquid : Uniquely designed for the Snow Machine SL-5A produces fast-dissipating "snowflakes" without leaving any residue behind.
- » 5 liter tank size is the same as the tank of SW-250 / S-100II / S-200 / S-120



Essence

Simply put a few drops of these high quality essence into the fluid tank. You will have scented fog right away! 5 fragrances are available in a standard 20 ml bottle. The ideal mix ratio of essence and fog liquid is 1:1000 For instance: adding 1ml essence into 1liter fog liquid can have the best effect of scented fog.

- P-1 : Rose P-2 : Mint P-4 : Apple
P-6 : Lemon P-7 : Strawberry



FLM-05 / M-1 Fog Liquid

The FLM-05 is the Fog liquid especially tailored for M-1 Fogger, with best quality no artificial colors are added and can generates the best, pure, and clean fog when goes with the M-1 model! It is 500 c.c. per bottle.



MG-550 Magican

The world's smallest spray hazer; the Magican produces a long-lasting haze with 1-2 hours of hanging time. One Magician will haze continuously for five minutes. A haze effect can be achieved after approximately 20 seconds of spraying in an average sized room, allowing for approximately 15 hazing sessions per can. The Magican is designed for situations where only a relatively small amount of haze is needed. It is perfect for mobile DJs and home parties.

CONTROL MODULE



W-1 Wireless Radio Transmitter

- » Working Distance : Wireless, up to 50 M
- » Function : Wireless ON/OFF
- » There are 2 radio frequencies can be chosen. They are 315MHz and 433MHz respectively.
- » Compatible With : W-101, W-508, W-510, W-515, W-530, IP-1500, HZ-350, SW-250, AF-5

Main Features:

1. Simple setting and operation : one click to register ; one click to go ; and one click to stop.
2. Interchangeability : A W-1 wireless radio transmitter is compatible with all Antari W series (signal receivers)
3. Modern metallic design honors your vision and professional.



X-30PRO

- » Cable Length : 2 M
 - » Working Distance : Wireless, up to 50 M
 - » Connector : 5 Pin XLR
 - » For W-1 Wireless Transmitter, there are 2 radio frequencies can be chosen. They are 315MHz and 433MHz respectively.
 - » Compatible With : Full X-PRO Series
- The X-30PRO Wireless Control Module, as its name suggests, adds wireless operation to your X-PRO Series machines . The X-30PRO delivers radio frequency technology you can depend on. You have the flexibility of wireless technology and the functionality you expect from Antari.

PRO



Z-20

- » Cable Length : 2 M
- » Connector : 5 Pin XLR
- » Function : Timer with interval, duration and volume; set DMX address; continuous fogging; manual ON/OFF. (All above functions are displayed on a LCD screen and can be set precisely in seconds or percentage)
- » Compatible With : Z-1500II, Z-3000II



Z-30PRO

- » Cable Length : 2 M
 - » Working Distance : Wireless, up to 50 M
 - » Connector : 5 Pin XLR
 - » For W-1 Wireless Transmitter, there are 2 radio frequencies can be chosen. They are 315MHz and 433MHz respectively.
 - » Compatible With : Z-1500II, Z-3000II
- The Z-30PRO Wireless Control Module, as its name suggests, adds wireless operation to your Z-Series machines . The Z-30PRO delivers radio frequency technology you can depend on. You have the flexibility of wireless technology and the functionality you expect from Antari.

PRO

 Wireless distance may vary depends on the interference.

CONTROL MODULE



M-20

- » Cable Length : 2 M
- » Connector : 5 Pin XLR
- » Function : Timer with interval, duration and volume; set DMX address; continuous fogging; manual ON/OFF. (All above functions are displayed on a LCD screen and can be set precisely in seconds or percentage)
- » Compatible With : M-5, M-10



D-20

- » Cable Length : 2 M
- » Connector : 5 Pin XLR
- » Function : Timer with interval, duration and volume; 4 Volume output choices (with non-stop fogging); Set DMX addresses; manual ON/OFF. (All above functions are displayed on a LCD screen & can be set precisely in seconds or percentage)
- » Compatible With : DNG-200



M-30PRO

- » Cable Length : 2 M
 - » Working Distance : Wireless, up to 50 M
 - » Connector : 5 Pin XLR
 - » For W-1 Wireless Transmitter, there are 2 radio frequencies can be chosen. They are 315MHz and 433MHz respectively.
 - » Compatible With : M-5, M-10
- The M-30PRO Wireless Control Module, as its name suggests, adds wireless operation to your M Series machines. The M-30PRO delivers radio frequency technology you can depend on. You have the flexibility of wireless technology and the functionality you expect from Antari.



X-10PRO

- » Cable Length : 2 M
- » Connector : 5 Pin XLR
- » Function : Timer with interval, duration and volume; set DMX address; continuous fogging; manual ON/OFF. (All above functions are displayed on a LCD screen and can be set precisely in seconds or percentage)
- » Compatible With : Full X-PRO Series
- » DMX Channel used : 1 channel for X-510PRO / X-515PRO Fogger; 2 channels for X-310PRO Fazer

 Wireless distance may vary depends on the interference.

REMOTES

Z-6 Timer Remote

- » Cable Length : 25 ft
- » Connector : 5 Pin DIN
- » Function : Timer with volume and duration; Continuous Hazing; manual ON/OFF
- » Compatible With : Z-300II



Z-8 Timer Remote

- » Cable Length : 25 ft
- » Connector : 4 Pin XLR
- » Function : Timer with interval, duration and volume; continuous fogging; manual ON/OFF
- » Compatible With : Z-1200II, LCU-1, ICE-101



Z-40 Timer Remote

- » Cable Length : 25 ft
- » Connector : 1/4 Stereo
- » Function : Timer with interval and duration; manual ON/OFF
- » Compatible With : Z-800II, Z-1000II, Z-1020



Z-50 Wireless Remote

- » Working Distance : Wireless, up to 50 M
- » Connector : 1/4 Stereo
- » Function : Wireless ON/OFF
- » Compatible With : Z-800II, Z-1000II, Z-1020



Z-9 Wireless Remote

- » Working Distance : Wireless, up to 50 M
- » Connector : 4 Pin XLR
- » Function : Wireless ON/OFF
- » Compatible With : Z-1200II, LCU-1



BCR-1 Wireless Remote

- » Working Distance : Wireless, up to 50 M
- » Connector : 1/4 Stereo
- » Function : Wireless ON/OFF
- » Compatible With : B-100X, B-200



BCT-1 Timer Remote

- » Cable Length : 25 ft
- » Connector : 1/4 Stereo
- » Function : Timer with interval and duration; manual ON/OFF
- » Compatible With : B-100X, B-200



HC-1 Timer Remote

- » Cable Length : 25 ft
- » Connector : 1/4 Stereo
- » Function : Timer with interval and duration; manual ON/OFF
- » Compatible With : HZ-100, HZ-350, HZ-400



SC-2 Remote

- » Cable Length : 25 ft
- » Connector : 4 Pin XLR
- » Function : ON/OFF and volume
- » Compatible With : S-100II, S-200, SW-250



HCR-1 Wireless Remote

- » Working Distance : Wireless, up to 50 M
- » Connector : 1/4 Stereo
- » Function : Wireless ON/OFF
- » Compatible With : HZ-100, HZ-400



MCR-1 Wireless Remote

- » Working Distance : Wireless, up to 50 M
- » Connector : 4 Pin S Terminal
- » Function : Wireless ON/OFF
- » Compatible With : M-1



Z-10 Remote

- » Cable Length : 25 ft
- » Connector : 1/4 Stereo
- » Function : ON/OFF (Toggle Switch)
- » Compatible With : Z-800II, Z-1000II, Z-1020, B-100X, B-200, HZ-350



» Wireless distance may vary depends on the interference.

ACCESSORIES

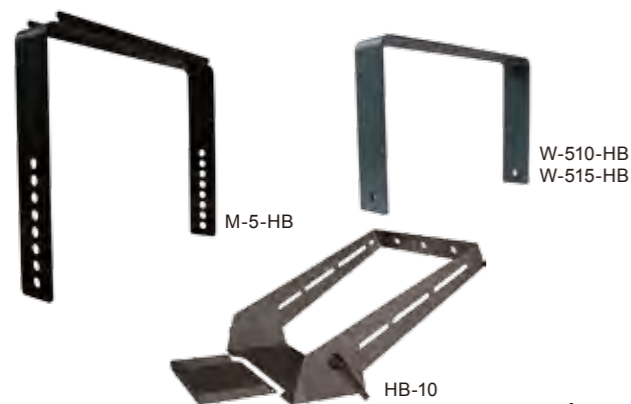

Hanging Bracket Sets

- » HB-10 : Hanging Bracket and Drip Tray For X-510PRO & X-515PRO
- » M-5-HB : Hanging Bracket For M-5
- » W-510-HB : Hanging Bracket For W-510
- » W-515-HB : Hanging Bracket For W-515, W-530

Liquid Tubes/Adaptors/Filters

- » FT-4 : 4mm liquid tube
- » FT-6 : 6mm liquid tube
- » FLF-4 : Liquid filter for 4mm tube
- » FLF-6 : Liquid filter for 6mm tube
- » FTA-64 : Adaptor for 4mm to 6mm tube connection
- » FTA-66 : Adaptor for 6mm to 6mm tube connection
- » FTA-664 : T-type adapter for two 6mm tubes to one 4mm tube connection



EXT-1

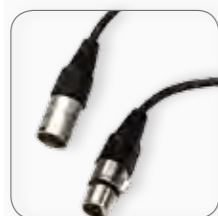

EXT-3/4/6



EXT-5

Remote Control Extension Cables

- » EXT-1 : 25 ft. extension cable with 1/4 stereo plug
- » EXT-3 : 25 ft. extension cable with 5-pin XLR connectors
- » EXT-4 : 25 ft. extension cable with 3-pin XLR connectors
- » EXT-5 : 25 ft. extension cable with 5-pin DIN connectors
- » EXT-6 : 25 ft. extension cable with 4-pin XLR connectors



FTA-1

FTA-2A

FTA-3

Fog Hose Adaptor

Adaptor for connecting fog conducting hose FT-10 for DNG-100 Fog Cooler to the desired Antari fog machine.

- » **FTA-1** : Adaptor for connecting fog conducting hose FT-10 to X-510PRO, X-515PRO, M-5, M-10, W-510, W-515 and W-530 fog machines, in order to achieve strategic fog placement.
- » **FTA-2A** : The same function as the FTA-1, specifically designed for Z-1000II and Z-1200II fog machines.
- » **FTA-3** : The same function as the FTA-1, specifically designed for Z-1500II and Z-3000II fog machines.

Fog Conducting Hose FT-10

Fog conducting hose with 12cm diameter and is 10 meters in length. The DNG-100 Low fog cooler is equipped with one FT-10 to connect to the fog machine. This additional hose is needed to redirect the fog output coming out of the DNG-100. With this optional hose, fog can be extended anywhere within 10m of the DNG-100.



FTA-200 Fog Conducting Hose Adaptor

Fog conducting hose adaptor for DNG-200. 2 "CODNG0600" hoses can be installed on it and this can split low fog output into two.

FLIGHT CASE



1. FM-5

- » Dimensions (mm) : L 805 W 433 H 310
- » Weight : 13 Kg
- » Compatible With : M-5



2. FM-10

- » Dimensions (mm) : L 824 W 433 H 332
- » Weight : 14.2 Kg
- » Compatible With : M-10



3. FX-310

- » Dimensions (mm) : L 750 W 358 H 403
- » Weight : 11.7 Kg
- » Compatible With : X-310PRO



4. FX-510

- » Dimensions (mm) : L 669 W 328 H 307
- » Weight : 9.3 Kg
- » Compatible With : X-510PRO



5. FX-515

- » Dimensions (mm) : L 764 W 328 H 363
- » Weight : 10.9 Kg
- » Compatible With : X-515PRO



7. FDNG-200

- » Dimensions (mm) : L 865 W 695 H 1020
- » Weight : 46.5 Kg
- » Compatible With : DNG-200



6. FZ-1020

- » Dimensions (mm) : L 530 W 390 H 438
- » Weight : 9.5 Kg
- » Compatible With : Z-1020 x 2 Units



8. FW-500

- » Dimensions (mm) : L 734 W 411 H 388
- » Weight : 13.5 Kg
- » Compatible With : W-515, W-530

| MODEL | POWER | FUSE (120V MODEL) | FUSE (230V MODEL) | WARM UP TIME | FOG OUTPUT (Cuft / min) | TANK (LITER) | HANGING BRACKET | REMOTE CONTROL INCLUDED |
|----------|--------------------|----------------------|----------------------|--------------------|----------------------------|-----------------|--------------------|----------------------------|
| AF-5 | 1500W | 15A | 7A | N/A | N/A | N/A | YES | W-1 (For AF-5R Model Only) |
| B-100 | 25W | 2A | 1A | N/A | N/A | 1.0 | YES | N/A |
| B-100X | 36W | 2A | 1A | N/A | N/A | 1.0 | YES | N/A |
| B-200 | 100W | 2A | 1A | N/A | N/A | 1.5 | YES | N/A |
| DNG-100 | 750W | 10A(Breaker) | 10A(Breaker) | N/A | N/A | N/A | N/A | N/A |
| DNG-200 | 1450W(120V) | 15A(DNG;Breaker) | 15A(Heater;Breaker) | 24min(120V) | 12000 | 10 | N/A | D-20 |
| DNG-200 | 2500W(230V) | 10A(DNG;Breaker) | 15A(Heater;Breaker) | 12min(230V) | 12000 | 10 | N/A | D-20 |
| F-3 | 800W | 10A | 5A | 100 Sec | 3000 | 2.7 | N/A | N/A |
| HZ-100 | 75W | 2A | 1.25A | N/A | 1000 | 2.5 | N/A | N/A |
| HZ-350 | 375W | 7A | 5A | N/A | 2000 | 2.5 | N/A | W-1 |
| HZ-400 | 560W | 7A | 5A | N/A | 2800 | 2.5 | N/A | HC-1 |
| HZ-500 | 500W | 7A | 5A | N/A | 3000 | 2.5 | N/A | N/A |
| ICE-101 | 1000W | 10A | 5A | 4.5min | 10000 | 2.5 | N/A | Z-8 |
| IP-1000 | 1000W | 15A(Breaker) | 7A(Breaker) | 10min | 10000 | N/A | N/A | IP-10 |
| IP-1500 | 1500W | 15A(Breaker) | 10A(Breaker) | 10min | 20000 | N/A | N/A | W-1 |
| LCU-1 | 54W | 2A | 1A | Machine Dependable | N/A | N/A | N/A | Machine Dependable |
| M-1 | 75W / 12V | N/A | N/A | N/A | 300 | 110cc | N/A | N/A |
| M-5 | 1500W | 15A(Breaker) | 7A(Breaker) | 8min | 20000 | 10 | Optional | M-20 |
| M-10 | 3000W | N/A | 15A(Breaker) | 13min | 40000 | 10 | N/A | M-20 |
| S-100II | 1130W (Max Output) | 10A | 5A | N/A | 140 ml / min | 5.0 | YES | SC-2 |
| S-120 | 1130W (Max Output) | 10A | 5A | N/A | 320 ml / min | 5.0 | YES | N/A |
| S-200 | 1130W (Max Output) | 10A | 5A | N/A | 140 ml / min | 5.0 | YES | SC-2 |
| SW-250 | 1290W (Max Output) | 10A | 5A | N/A | 240 ml / min | 5.0 | YES | W-1 |
| W-101 | 25W | 2A | 1A | N/A | N/A | 1.0 | YES | W-1 |
| W-508 | 800W | 7A | 4A | 1.5min | 3000 | 0.8 | N/A | W-1 |
| W-510 | 1000W | 10A | 5A | 12min | 10000 | 2.8 | Optional | W-1 |
| W-515 | 1500W | 15A(Breaker) | 7A(Breaker) | 10min | 20000 | 6 | Optional | W-1 |
| W-530 | 3000W | N/A | 15A(Breaker) | 12min | 40000 | 6 | N/A | W-1 |
| X-310PRO | 1000W | 10A | 5A | 10min | 3500 | 2.4 | N/A | X-10PRO |
| X-510PRO | 1000W | 10A | 5A | 11min | 10000 | 2.8 | N/A | X-10PRO |
| X-515PRO | 1500W | 15A(Breaker) | 7A(Breaker) | 8.5min | 20000 | 6.0 | Optional | X-10PRO |
| Z-300II | 700W | 7A | 3.15A | 4.0min | 2000 | 1.3 | N/A | Z-6 |
| Z-800II | 800W | 7A | 4A | 1.5min | 3000 | 0.8 | N/A | Z-10 |
| Z-1000II | 1000W | 10A | 5A | 5.5min | 10000 | 1.7 | YES | Z-10 |
| Z-1020 | 1000W | 10A | 5A | 10min | 10000 | 2.4 | N/A | Z-10 |
| Z-1200II | 1200W | 15A(Breaker) | 7A(Breaker) | 9min | 18000 | 2.5 | YES | Z-8 |
| Z-1500II | 1500W | 15A(Breaker) | 7A(Breaker) | 8.5min | 20000 | 6.0 | N/A | Z-20 |
| Z-3000II | 3000W | N/A | 15A(Breaker) | 12min | 40000 | 6.0 | N/A | Z-20 |

| MODEL | TIMER REMOTE | WIRELESS REMOTE | 25 ft. REMOTE EXTENSION | COMPATIBLE WITH DNG-100 | DNG-100 ADAPTOR | MACHINE LINKABLE | DMX ON-BOARD |
|----------|------------------|----------------------------|----------------------------|----------------------------|--------------------|---------------------|-----------------|
| AF-5 | N/A | W-1 (For AF-5R Model Only) | N/A | NO | N/A | YES | YES |
| B-100 | N/A | N/Z | N/A | NO | N/A | N/A | N/A |
| B-100X | BCT-1 (Optional) | BCR-1 (Optional) | EXT-1 | NO | N/A | N/A | N/A |
| B-200 | BCT-1 (Optional) | BCR-1 (Optional) | EXT-1 | NO | N/A | YES | YES |
| DNG-100 | N/A | N/A | N/A | - | - | N/A | N/A |
| DNG-200 | D-20 | N/A | EXT-3 | - | - | YES | YES |
| DNG-200 | D-20 | N/A | EXT-3 | - | - | YES | YES |
| F-3 | N/A | N/A | N/A | NO | N/A | YES | YES |
| HZ-100 | HC-1 | HCR-1 (Optional) | EXT-1 | NO | N/A | N/A | N/A |
| HZ-350 | N/A | W-1 | EXT-1 | NO | N/A | YES | YES |
| HZ-400 | HC-1 | HCR-1 (Optional) | EXT-1 | NO | N/A | YES | YES |
| HZ-500 | N/A | N/A | N/A | NO | N/A | YES | YES |
| ICE-101 | Z-8 | N/A | EXT-6 | NO | N/A | YES | YES |
| IP-1000 | N/A | N/A | N/A | NO | N/A | N/A | N/A |
| IP-1500 | N/A | W-1 | N/A | YES | FTA-1 | YES | YES |
| LCU-1 | Z-8 (Optional) | Z-9 (Optional) | EXT-6 | NO | N/A | YES | YES |
| M-1 | MCT-1 (Optional) | MCR-1 (Optional) | N/A | NO | N/A | N/A | N/A |
| M-5 | M-20 | M-30 (Optional) | EXT-3 | YES | FTA-1 | YES | YES |
| M-10 | M-20 | M-30 | EXT-3 | YES | FTA-1 | YES | YES |
| S-100II | SC-2 | N/A | EXT-6 | NO | N/A | YES | YES |
| S-120 | N/A | N/A | N/A | NO | N/A | N/A | N/A |
| S-200 | SC-2 | N/A | EXT-6 | NO | N/A | YES | YES |
| SW-250 | N/A | W-1 | EXT-6 | NO | N/A | YES | YES |
| W-101 | N/A | W-1 | N/A | NO | N/A | N/A | N/A |
| W-508 | N/A | W-1 | N/A | NO | N/A | N/A | N/A |
| W-510 | N/A | W-1 | N/A | YES | FTA-1 | YES | YES |
| W-515 | N/A | W-1 | N/A | YES | FTA-1 | YES | YES |
| W-530 | N/A | W-1 | N/A | YES | FTA-1 | YES | YES |
| X-310PRO | X-10PRO | X-30PRO (Optional) | EXT-3 | NO | N/A | YES | YES |
| X-510PRO | X-10PRO | X-30PRO (Optional) | EXT-3 | YES | FTA-1 | YES | YES |
| X-515PRO | X-10PRO | X-30PRO (Optional) | EXT-3 | YES | FTA-1 | YES | YES |
| Z-300II | Z-6 | N/A | EXT-5 | NO | N/A | N/A | N/A |
| Z-800II | Z-40 (Optional) | Z-50 (Optional) | EXT-1 | NO | N/A | N/A | N/A |
| Z-1000II | Z-40 (Optional) | Z-50 (Optional) | EXT-1 | YES | FTA-2A | YES | YES |
| Z-1020 | Z-40 | Z-50 (Optional) | EXT-1 | NO | N/A | YES | YES |
| Z-1200II | Z-8 | Z-9 (Optional) | EXT-6 | YES | FTA-2A | YES | YES |
| Z-1500II | Z-20 | Z-30PRO (Optional) | EXT-3 | YES | FTA-3 | YES | YES |
| Z-3000II | Z-20 | Z-30PRO (Optional) | EXT-3 | YES | FTA-3 | YES | YES |