



Python KP102

3D line-array element,
variable beam speaker

FEATURES

- Unique performance-to-size ratio
- Vertical, Horizontal and 3D line-array applications
- Multiple 3.15" long-excursion full-range cone drivers
- Wide horizontal coverage
- Electronically protected
- Selectable 4 Ohm or 16 Ohm impedance
- Selectable vertical pattern (Spot - Flood)
- Weather proof, suitable for outdoor installations - IP54

APPLICATIONS

- Theatre, Club, House of worship
- Front fill and under-balcony fill
- Portable and installed AV systems
- Stage and AV studio monitoring

ACCESSORIES

KP-CASE, K-BASE2, K-FLY2, KP-CLUSTER2, K-FOOT2, K-JOINT2, KP-STAGE, K-WALL2L, K-WALL2, K-KCLAMP/S, K-KCLAMP,

COLORS AVAILABLE

BLACK  WHITE 



DESCRIPTION

The K-array KP102 is a passive speaker system comprised of twelve 3.15" neodymium magnet transducers housed in an elegant and sturdy stainless steel chassis. The vertical dispersion pattern can be switched for wide or narrow coverage, allowing for a great variety of applications. The twelve closely spaced cone drivers provide true line array characteristics - phase coherence, low distortion and focused listening in both the near field, and at a distance from the speaker. A variety of rigging accessories provides many linking and hanging options for the KP52 (0.5 meter) and the larger (1 meter) KP102 to be combined in vertical and horizontal line array configurations to satisfy many different venue requirements during temporary events and for permanent installations.

For easier use and integration with other speakers or amplifiers, the KP102 allows the user to select two different values of

impedance (4Ω - 16Ω). At 16Ω as many as 4 KP102 speakers can be powered off a single amplifier channel at 4 Ω (up to 2 units @ 8Ω), which eliminates the need of 70 V amplifiers for wider distributed installed systems.

The KP102 is able to reproduce the whole vocal frequency range with high intelligibility, starting from 100 Hz. Integrating one of the K-array powered subwoofers (KMT12, KMT18, KMT21, KMT218), configured with specific presets for the KP102 assures excellent coverage of the entire musical frequency range.

The K-array KA amplifier series have presets optimized for KP102.

All KP102 components are designed by the K-array R&D department and custom-made under the K-array quality control system.



	ACOUSTICS		TRANSDUCERS
Power handling	720 W ^(AES)	Full range	12 x 3.15" Neodymium magnet with 1" voice coil
Max power	1200W		SELECTION SWITCHES
Frequency Range	100 Hz – 20 kHz (- 10dB) ⁽¹⁾	Impedance	4 Ω / 16 Ω
Impedance	4 Ω / 16 Ω (selectable)	Coverage	Spot / Flood
SPL 1W/1mt	99 dB ⁽²⁾		POWER AUDIO INPUT/LINK
Maximum SPL	128 dB (cont.) – 134 dB (peak)	Connector	2 x 4-pin Speakon
	COVERAGE	Wiring	1+ 1- (signal IN & LINK); 2+ 2- (through)
Horizontal	90°		RECOMMENDED AMPLIFIERS
Vertical	7°- 30° (selectable)	Type	KA84, KMT
	CROSSOVER		CERTIFICATION
Type	External Crossover required	IP	54
Frequency	100 Hz, 24 dB/oct suggested minimum		PHYSICAL
		Dimensions	8.9 x 100.0 x 11,8 cm (3.5" x 39.4" x 4.6")
		Weight	12 kg (26.5 lbs)

Notes for data

1. With dedicated preset;
2. Measured @4 mt then scaled @1 mt;
3. Measured with musical signal

New materials and design are introduced into existing products without previous notice. Present systems may differ in some respects from those presented in this catalogue.

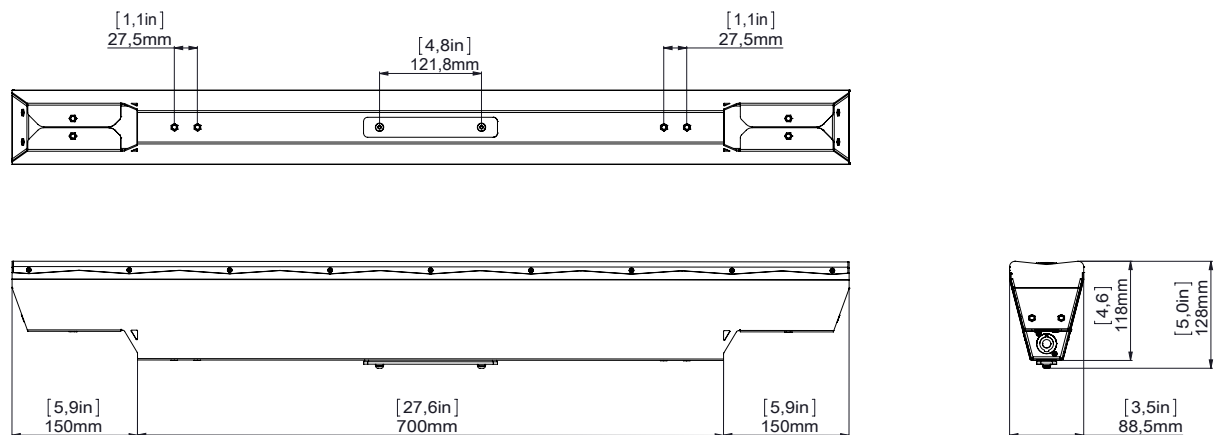

ARCHITECT SPECIFICATIONS

The mid-high passive speaker shall be one of the most compact in the market with a remarkable power, compared with the size. It shall consist of twelve 3.15" long-excursion full range cone drivers with a neodymium magnet assembly mounted in a 100 cm (39.4") array on a sturdy turned aluminum cabinet enclosure which shall be all weather resistant and durable and suitable for both outdoor and indoor applications. The speaker shall allow settings of two different impedance values, for a higher or lower impedance use (4Ω / 16Ω if possible). The loudspeaker shall only be operated by a compatible amplifier with dedicated

presets loaded onboard. The cones shall be protected only by a rigid metal grill and without any other backing material that could effect the quality and safety. The cabinet of the speaker shall feature a dedicated aluminum bracket or two different threaded anchor points to be installed on a wall or under a ceiling. The speaker shall be able to be integrated with other units of the same model and, when required, with a suitable subwoofer to extend its frequency range for more demanding applications. The connectors shall be recessed and fitted with two 4-pin Speakon sockets. The loudspeaker shall have a nominal horizontal dispersion angle of 90° and

a vertical one of 7°/30° in order to avoid unpleasant acoustic reflections from both the ceiling and the floor. The power handling capacity shall be 720W^{AES} with a max power of 1200 W^{RMS}. The frequency response (+/- 10dB) measured on axis shall be 100 Hz to 20 kHz with a maximum sound pressure of 134 dB (peak). The speaker shall be as invisible as possible and shall be easily integrated in any kind of environments and surfaces. The dimensions (WxHxD) shall not exceed 89 x 1000 x 118 mm (3.5" x 39.4" x 4.6") and shall weigh no more than 12 kg (26.5 lbs). The loudspeaker shall be the KP102 by K-array surl.