

Wallrack

Wall Mount Digital Dimming Panels

Designed for the 230/240V markets, Strand Lighting Wallrack digital dimming panels define the new standard in permanent installation dimming for small/medium entertainment and architectural venues, the Wallrack digital dimming panels are available in three sizes. Wallrack digital dimming panels are convection cooled (no fans) and yet extremely compact – great for distributed dimming schemes or just to get a lot of dimmers into a small space!

All versions of the Wallrack digital dimming panel are provided with plug-in control processors – stylish, easy to use, and very easy to maintain. Wallrack digital dimming panels have dual DMX512 inputs, so you can use a Strand Lighting console on one input and an Accent DMX architectural control network on the other.

Wallrack digital dimming panels offer a simple panic feature too, for connection to emergency systems, or just for cleaners’ lights. All Wallrack digital dimming panels may be upgraded to earth-leakage protection at installation, using standard 4-pole RCDs.

Features

- 24 x 2.5kW, 6 x 2.5kW, and 6 x 5kW versions
- 220-240VAC, 3-phase/single phase operation
- MCB (SPN) protection for each channel
- Field-upgradeable to RCD protection
- Easy installation/compact size
- Convection cooled – no fans
- Substantially overrated power devices
- Dual DMX512 input, DMX512 patch and DMX512 output
- Powerful patch, with user-selectable curves and non-dims
- 8 remote preset closures and Panic input
- Up to 6 analogue outputs for external fluorescent or contactor operation
- Plug in control electronics for easy maintenance
- Ample cable space for top or bottom entry
- Simple and intuitive software configuration
- LED indicators for 3 phases, DMX A and B, and Over-temperature
- Integral power supply for up to eight Accent DMX architectural control stations

Use a 4-pole 60 amp DIN rail mounting RCD, with DC pulse rating to upgrade the 6 x 5kW Wallrack digital dimming panel at time of installation. Note that the 24 x 2.5kW Wallrack digital dimming panel requires two RCDs.



Wallrack Digital Dimming Panel

PHILIPS
Strand Lighting

SPECIFICATION SUBMITTAL

CONSULTANT: <input type="text"/>	PROJECT NAME: <input type="text"/>	MODEL NUMBER QUANTITY: <input type="text"/> <input type="text"/> <input type="text"/> <input type="text"/> <input type="text"/> <input type="text"/>
DATE: <input type="text"/>	PROJECT NUMBER: <input type="text"/>	APPROVED BY: <input type="text"/>

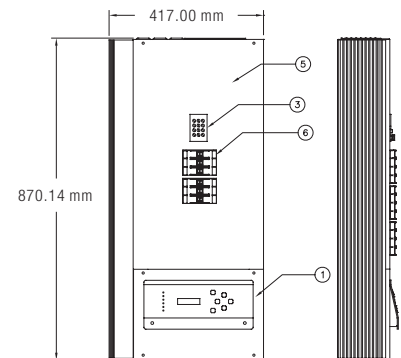
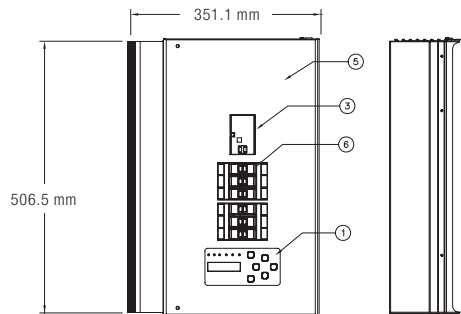
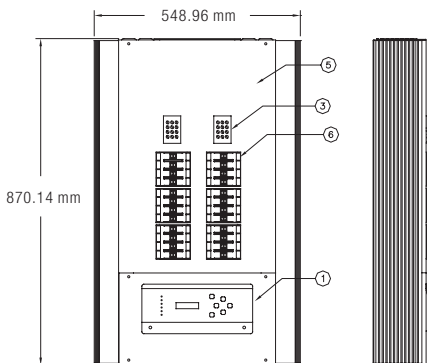
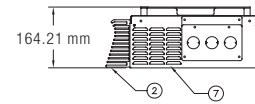
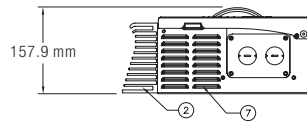
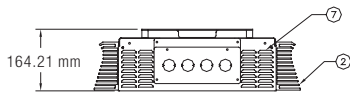

75356 Wallrack Dimming Panel
(24 x 2.5kW, 230V)

75357 Wallrack Dimming Panel
(6 x 2.5kW, 230V)

75358 Wallrack Dimming Panel
(6 x 5.0kW, 230V)

Legend:

- (1) Digital Main Processor unit
- (2) Heat Sinks
- (3) Main Feed terminal Blocks (Optional RCD Protection)
- (4) Load and Control Entry Points
- (5) Removable Front Panel
- (6) Dimmer Primary Circuit breakers
- (7) Intake & Exhaust Vents (no fans)

Note, drawings are not to scale.

Technical Specifications

Mechanical Data

Construction: Formed Steel Assembly

Dimensions:

75356: 870 (H) x 549 (W) x 164 (D) mm

75357: 507 (H) x 351 (W) x 158 (D) mm

75358: 870 (H) x 417 (W) x 164 (D) mm

DMX512: Dual DMX512 in, merged DMX512 out

Environmental Data

Temperature: 0 to 37°C

Humidity Range: 0 to 95% Non-condensing

Ingress Protection: IP30

Compliance:

EMC emissions to EN50081-1, EN55014; EMC immunity to EN50082-1, IEC1000-2-2; EN60950, EN60439 Part 1 (also part 12 BS5486); design & build: ISO9000
The unit is CE marked

Safety:

Electrical Data

Rise Time: 160µs toroidal filter chokes (24 x 2.5kW)

160µs toroidal filter chokes (6 x 2.5kW)

120µs toroidal filter chokes (6 x 5kW)

Supply Voltage: 230/240V 3 phase up to 80A

Ordering Information

Cat No. Description

Wallrack Digital Dimming Panels

75356 Wallrack Dimming Panel, 24 x 2.5kW 230V
75357 Wallrack Dimming Panel, 6 x 2.5kW 230V

75358 Wallrack Dimming Panel, 6 x 5.0kW 230V

Philips Strand Lighting

Dallas

10911 Petal Street
Dallas, TX 75238
Tel: (214) 647-7880
Fax: (214) 647-8031

New York

267 5th Ave, 4th Floor
New York, NY 10016
Tel: (212) 213-8219
Fax: (212) 532-2593

www.strandlighting.com

© Philips Group 2011
All rights reserved.
The Company reserves the right to make any variation in design or construction to the equipment described. E&OE

Auckland

19-21 Kawana Street
Northcote, Auckland 0627
New Zealand
Tel: + 64 9 481 0100
Fax: + 64 9 481 0100

Asia

Unit C, 14/F,
Roxy Industrial Centre
No. 41-49 Kwai Cheong Road
Kwai Chung, N.T., Hong Kong
Tel: + 852-2796-9786
Fax: + 852-2798-6545

Europe

European Service & Distribution Centre
Marssteden 152
Enschede 7547 TD
the Netherlands
Tel: +31-53-4500424
Fax: +31-53-4500425