

SL BEAM 300FX



The SL BEAM 300FX is a high performance moving head luminaire that delivers a powerful output, with fast and quiet movement. The 19 RGBW LEDs deliver exceptional output, and the versatile and effective precision optical design allows the SL BEAM 300FX to function both as beam luminaire, and as a wash luminaire.

Use as a beam luminaire: the SL BEAM 300FX delivers a crisp, tightly collimated beam at the narrow end (between 4° and 10°), and the dual rotating front lens and effect wheel creates a unique myriad of bright compositions.

Use as a wash luminaire: the SL BEAM 300FX delivers powerful blended washes of color, and entrancing, fluid lighting effects can be created with the lens and effects wheel.

Precise, controlled light: individual pixel control and carefully designed optics deliver full flexibility, and remove the need for inconvenient third party beam control accessories.

Configure the SL BEAM 300FX remotely via RDM, or locally through the comprehensive Showline LCD menu system.

Features:

- Rugged Construction
- 19pcs High Quality RGBW LEDs for exceptional output and color
- IP20 Rated
- Unique optical system, featuring unmatched zoom range (4° - 40°) and even, blended light distribution
- 540 degree pan and 230 degree tilt max
- 2.5s max for full pan movement and 1.5s min for full tilt movement
- 8 or 16 bit DMX-512A operation for smooth stepless fades
- On-board LCD Menu System for addressing and setup
- Remote configuration available via RDM
- 5 pin DMX-512A(RDM) IN and THRU connections
- RJ45 connector for DMX over Ethernet
- Neutrik PowerCon for power IN and THRU connections

Drawing Diagram:

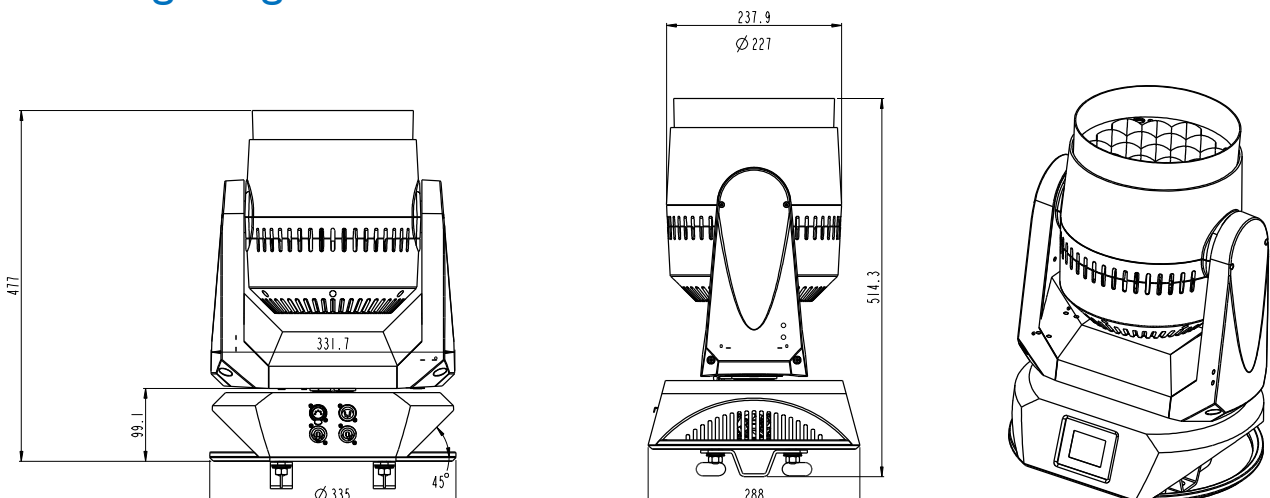

Technical Specifications:

Version:

SL BEAM 300 FX, IP20

Optics:

4-40 degree beam angle

19 high power RGBW LEDs

Controls:

DMX-512A(RDM)

Local LCD control

Master/Slave

Modes:

HSIC

RGBW 8 bit

RBGW 16 bit

Simple 8 bit

Pattern

Features:

540 degree pan and 230 degree tilt

Quiet active cooling

Harmonize color calibration

4 - 40 degree zooming range

2.5s max for full Pan movement and 1.5s min for full Tilt movement

Physical:

100 - 240VAC, 350W

335mm x 480mm x 290mm

14.5 kgs

CE/C-Tick/cETL

Luminance:

4500 lumens

CRI/CQS:

90 (RGBW)

Ordering Information:

88-095-6092-36

SL BEAM 300FX Moving head RGBW, IP20

SLBEAM300FX

Harmonize Color Calibration Technology

At the heart of all Showline products is Philips Harmonize Calibration technology. Harmonize is a proprietary, advanced LED color matching system, consisting of 3 correction modules: RGB, RGBW and CoolWhite/Warm White. Every Showline fixture undergoes rigorous testing to provide you with consistent control of color and intensity as well as output of the highest quality.

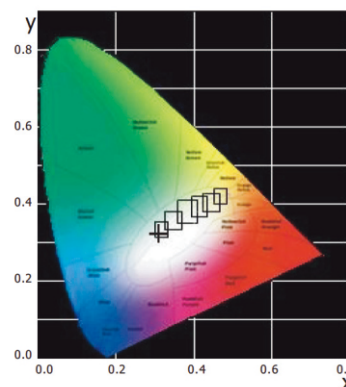

Philips Group 2014. All rights reserved.

The Company reserves the right to make any variation in design or construction to the equipment described. E&OE. Philips Entertainment delivers fully integrated lighting solutions; from simple lamps to complete systems designed with the specific needs of the entertainment and specialized display lighting markets. www.philips.com/showline

Philips Entertainment U.S.
10911 Petal Street Dallas,
TX 75238
U.S.A
Tel: +1 214647 7880 Fax:
+1 214647 8030

Philips Entertainment Lighting Asia Limited
Unit C, 14/F, Roxy Industry Centre
No. 41 - 49 Kwai Cheong Road
Kwai Chung, N.T. Hong Kong
Tel: +852 27969786
Fax: +852 27986546

Philips Entertainment Group Europe
Rondweg Zuid 85
Winterswijk 7102 JD Netherlands
Tel: +31 543-542343
Fax: +31 53 4500425

Philips Entertainment New Zealand
19 - 21 Kawana Street, Northcote
Auckland 0627, New Zealand
Tel: +64 9481 0100
Fax: +64 9481 0101